



INSTALLATION AND OPERATING MANUAL FOR THE WIND AIR CURTAIN (FOR INDUSTRIAL AND COMMERCIAL USE)



CONTENT

1.	General information	4
1.1.	Introduction	4
1.2.	Use of the unit	4
1.3.	Transport, inspection of delivery and storage	4
1.4.	Contents of the package	5
1.5.	Before start of installation	5
2.	Technical parameters	5
2.1.	WIND air curtain design	5
2.1.1.	AXIAL EC FANS	5
2.1.2.	WATER EXCHANGER	5
2.1.3.	CURTAIN CASING	5
2.1.4.	EXHAUST LAMELLAS	5
2.2.	Main dimensions and requirements for the minimum working space for the WIND curtain	6
2.3.	Technical data	7
2.4.	Technical data of water heaters	7
3.	Installation – installation of air curtains in the working position	8
3.1.	General information, recommendations and safety during installation of the Wind air curtain	8
3.1.1.	Electrical safety when installing the curtain	8
3.1.2.	Modification of existing heating distribution systems	8
3.1.3.	Load bearing capacity of the assembly site	8
3.1.4.	Minimum assembly distances	8
3.1.5.	Minimum safety distance from flammable substances	9
3.1.6.	Operation environment of the curtain	9
3.1.7.	Levelling of the curtain	9
3.2.	Ceiling installations	9
3.2.1.	Positioning the curtain in the working position	9
3.2.2.	Fixing the curtain to the floor	9
3.3.	Vertical installation - curtain chaining	10
3.3.1.	Chained curtain mounting	10
3.3.2.	Side anchoring of the chained assembly	11
3.3.3.	Maximum height of chained curtains	11
3.4.	Vertical installation – increased barrier effect	12
3.5.	Horizontal installation	12
3.5.1.	Preparation for the curtain suspension	12
3.5.2.	Determination of the installation site	13
3.5.3.	Auxiliary anchoring structures	13
3.5.4.	Correct installation in horizontal position	13
3.5.4.1.	Examples of Curtain Suspension – Horizontal Installation	14
3.5.5.	Measurement of anchoring holes	14
3.5.6.	Installation of the auxiliary anchoring structure	14
3.5.7.	Installation – hanging the curtain into the working position	14

3.6.	Horizontal installation - curtain chaining	15
3.6.1.	Installation of the auxiliary anchoring structure	15
3.6.2.	Determination of the installation location for the chained curtains	15
3.6.3.	Auxiliary anchoring structures for chained curtains	15
3.6.4.	Correct installation in horizontal position during curtain chaining	15
3.6.4.1.	Examples of curtain suspension - horizontal installation – chaining	17
3.6.5.	Measurement of anchoring holes for chained curtains	17
3.6.6.	Installation – suspension of the chained curtains into the working position.....	17
3.7.	Installation – suspension of the chained curtains into the working position.....	17
3.8.	Water exchanger connection	18
3.8.1.	Connection of the curtain to the hot water distribution system	18
3.8.2.	Water exchanger connection	18
3.8.3.	Venting (discharge) valve	19
3.8.4.	Example hydraulic diagram of unit connection	19
3.9.	Electrical installation and electrical connection	20
3.9.1.	General Information - Safety	20
3.9.2.	Connection of power supply and curtain control.....	20
3.9.3.	Description of power and control terminals – electrical diagram of motors	21
3.9.3.1.	Description of connection of 1 curtain	21
3.9.3.2.	Description of the curtain connection during the chaining	21
3.9.4.	Connection to the mains	22
3.9.5.	Display of electrical parameters on the curtain	22
4.	Regulation	22
4.1.	General Information – Safety	22
4.2.	Control elements	23
5.	Atacama heating unit wiring diagram	24
5.1.	Details of connecting the main terminal box to the regulator ELEMENTAIR-E-M1 and with the accessories.....	24
5.2.	Connection of the Wind curtain with the regulator ELEMENTAIR-E-M1.....	24
5.3.	Connection of chained Wind curtains with regulator ELEMENTAIR-E-M1	25
6.	Commissioning	26
6.1.	Before the first start check the following:.....	26
6.2.	Switching on	26
7.	Regular maintenance and cleaning of the WIND curtain	26
7.1.	Regular maintenance.....	26
7.2.	Cleaning procedure.....	26
8.	Service	27
8.1.	Troubleshooting procedure	28
9.	Decommissioning and recycling	28
10.	Warranty	29
11.	Conclusion	29

1. General information

1.1. Introduction

- This document "Installation and Operating Manual" is intended for the Wind air curtain (hereinafter the "curtain"), which is used to separate the interior from the external environment by a stream of air and for hot-air heating of the required space. Detailed familiarisation with this document is important for the correct and safe installation and functioning of the curtain. Failure to follow the conditions in this document may result in malfunction of the unit.
-  **The curtain may only be installed and connected by a trained person with the appropriate authorization to connect electrical equipment, which has available suitable tools and means. During the assembly, it is necessary to observe all the instructions and recommendations in this manual.**
- For the correct operation and long-term service life of the unit, it is necessary to prevent access to unauthorised persons and to train operators according to this document and applicable legislative regulations.
- The documentation must always be available at the place of installation for any service intervention. It is forbidden to interfere in any way with the internal connection of the curtain, which does not correspond to the instructions given in this manual. Due to the continuous development of our products, we reserve the right to change this manual without prior notice.

1.2. Use of the unit

- The Wind air curtain is designed to separate the interior from the environment by a stream of air. This prevents the internal air from leaking out of the internal environment to the external environment when the doors, gates, etc...are open. Other function of the curtain when the doors or gates are closed is to heat the internal space by hot-air heating. When purchasing accessories – filter, the curtain also serves to filter the air in the inner environment.
- The curtain is intended mainly for entrances to industrial halls, warehouses, sports facilities, workshops, smaller facilities and commercial premises.
- The curtain is designed for indoor covered and dry areas with ambient temperatures between 5°C and +40°C.
- The curtain may also be used for environments with a higher non-condensing humidity corresponding to the protection class IP54 and IP44 according to EN 60529, depending on the type of curtain. However, the maximum allowed humidity is 80%. The curtain may also be used in corrosive environment C2 according to EN ISO 9223. The curtain must not be operated in an environment with the risk of explosion and increased dustiness.
- Neither the manufacturer nor the supplier is liable for damage caused by improper use of the curtain. The risk is borne by the user alone.
- The curtain must not be operated during finishing construction activities, especially during activities that create excessive dustiness, e.g. by grinding concrete, plasterboard, etc...

1.3. Transport, inspection of delivery and storage

- Before starting the installation and before unpacking the unit from the box, it is necessary to check for any traces of damage on the packaging. In case of damage to the packaging, please contact your carrier.
- Check if the product ordered by you is in agreement. After unpacking, check that the unit and other components are intact. Please report any non-conformity with the order to the supplier immediately. If an order complaint is not made immediately after delivery, it will not be taken into account later.
- If you do not install the unit immediately after purchase, it must be stored in an indoor, non-condensing environment at temperatures in the range of 5 to 40°C. If the product has been transported at temperatures below 5°C, it must be stored after unpacking for at least 2 hours in the working environment where it will be installed.

-  **Use adequate tools to prevent damage to the goods and to avoid health and safety risks of persons.**

1.4. Contents of the package

WIND 1 air curtain	1x
Quick manual + Safety Data Sheet	1x
Name plate	1x

1.5. Before start of installation

- Before starting the installation, we recommend that you attach the serial nameplate (normally delivered with the unit in its package) to the operational documentation (e.g.: equipment operating book, etc.), which is subsequently kept for a later maintenance record and the respective servicing.
- **Before starting all installation or maintenance work, it is necessary to switch off the power supply and secure the switch against switching it on again.**



2. Technical parameters

2.1. WIND air curtain design

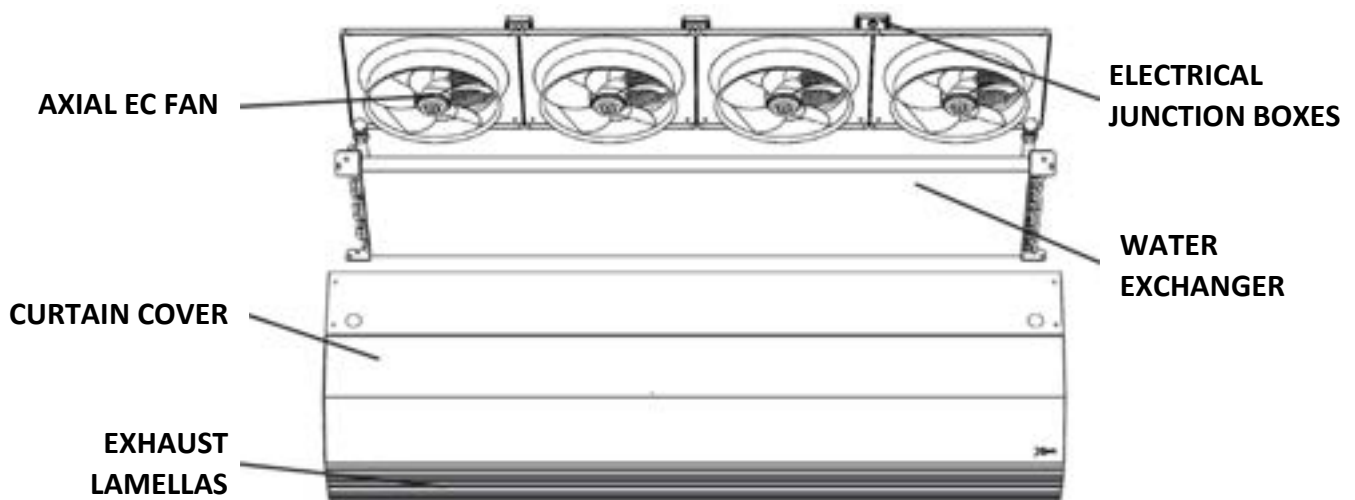

2.1.1. AXIAL EC FANS

The maximum operating temperature of the fan motor is + 60°C, operating humidity 0-90% non-condensing, protection class IP54 and IP44 according to the selected curtain type, and the motor insulation class B. The fan and its board are treated with powder coating RAL 9005.

2.1.2. WATER EXCHANGER

Maximum permissible temperature/pressure of heating medium 120°C / 1.6MPa. The exchanger consists of an aluminium - copper structure. Water exchanger is connected by connectors with mail thread 1". The exchanger is equipped with a venting valve on both collectors.

2.1.3. CURTAIN CASING

The sheet metal casing of the curtain consists of two parts. The rear part towards the fan is in RAL 9005 colour. The front part towards the exhaust lamellas is in RAL 7016 colour.

2.1.4. EXHAUST LAMELLAS

The exhaust lamellas are designed from aluminum profiles, which are provided against corrosion and mechanical damage by "anodizing" (artificial corundum). They are not used to deflect the air stream. The air flow redirection is tackled in Chapter 3.7.

2.2. Main dimensions and requirements for the minimum working space for the WIND curtain

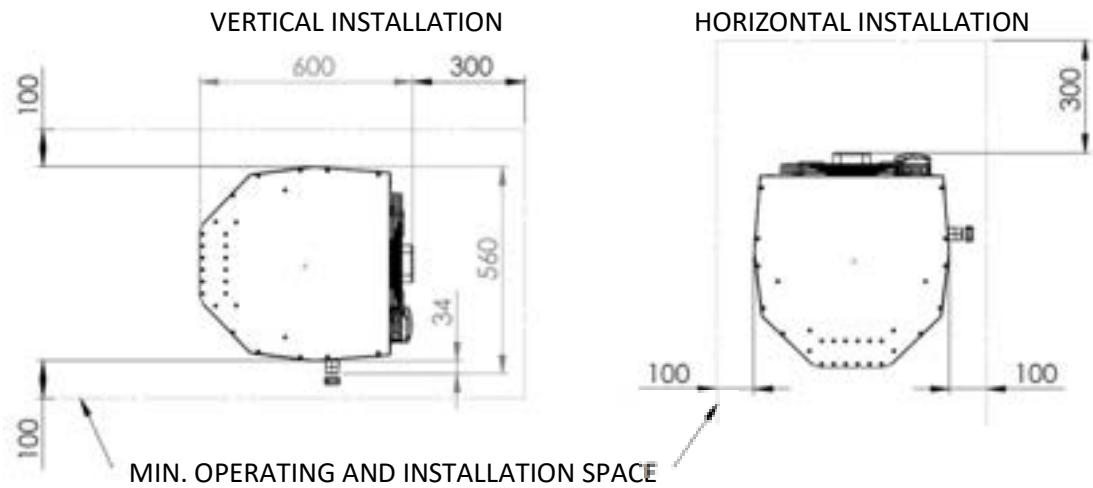
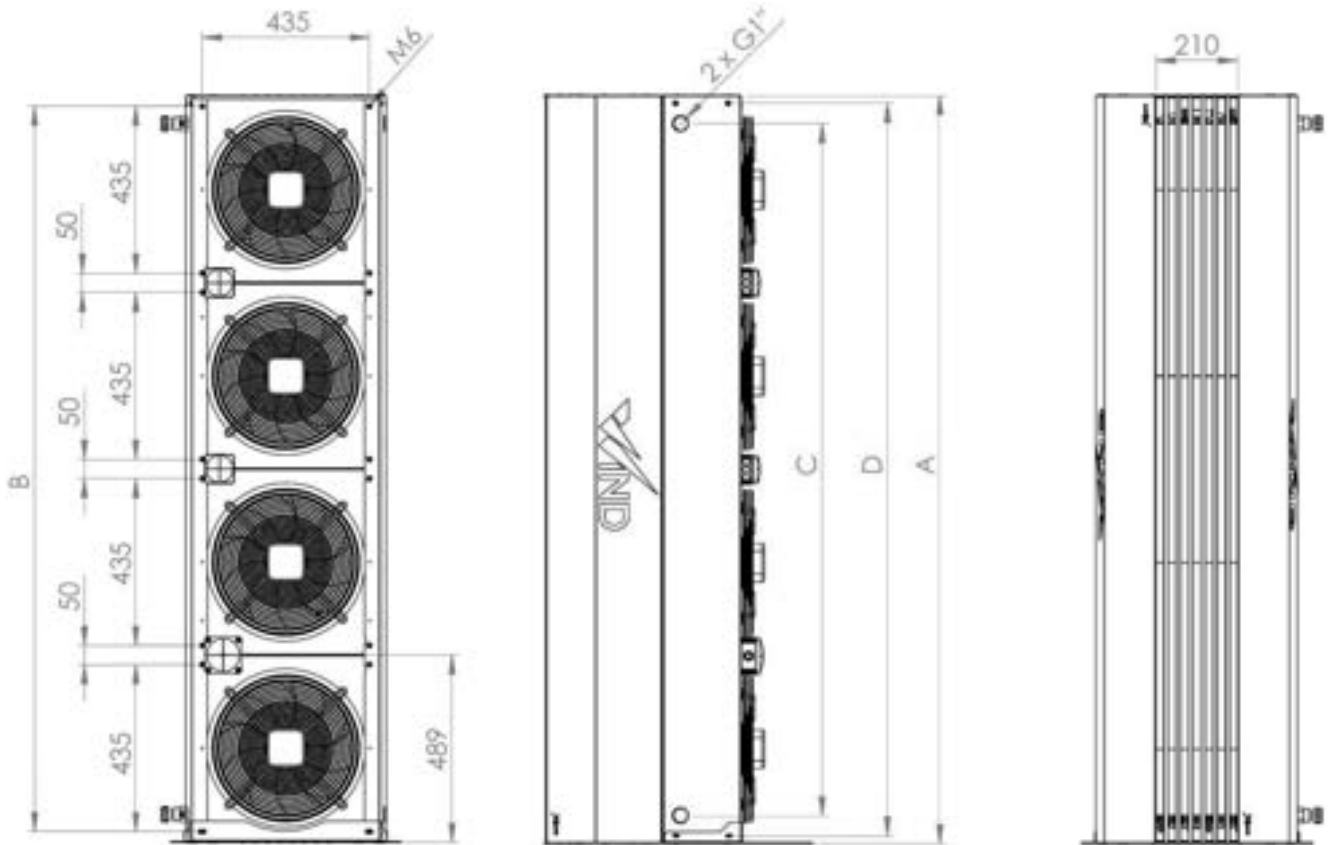

	WIND-15A,B-S0	WIND-15A,B-V2	WIND-20A,B-S0	WIND-20A,B-V2	WIND-25A,B-S0	WIND-25A,B-V2
A	1465 mm	1465 mm	1950 mm	1950 mm	2435 mm	2435 mm
B	1405 mm	1405 mm	1890 mm	1890 mm	2375 mm	2375 mm
C	-	1315 mm	-	1800 mm	-	2285 mm
D	1420 mm	1420 mm	1906 mm	1906 mm	2390 mm	2390 mm

2.3. Technical data

Name	Motor type	WIND-15				WIND-20				WIND-25			
		EC				EC				EC			
Airflow	m ³ /h	7750	6750	9000	7800	10350	9000	12000	10400	12900	11250	15000	13000
Heat output range	kW	-	6 - 63	-	8 - 69	-	8 - 86	-	11 - 94	-	10 - 107	-	13 - 117
Number of heat exchanger rows	-	-	2	-	2	-	2	-	2	-	2	-	2
Heat exchanger data													
maximum operating water temperature 120 °C; maximum operating pressure 1,6MPa; pipe connection dimension G 1"													
Maximum horizontal blowing distance *	m	7	6,5	8	7	7	6,5	8	7	7	6,5	8	7
Maximum vertical blowing distance *	m	6	6	7	6	6	6	7	6	6	6	7	6
Noise level **	dB(A)	49,9	49	60,9	58,8	52	51	62,7	60,6	53,2	52,3	63,7	61,7
Unit weight ***	kg	42,8	54	44,4	56	47,7	57,8	53,9	64	71,1	83,5	78,6	91
The volume of water in the exchanger	dm ³	-	3,4	-	3,4	-	4,6	-	4,6	-	5,7	-	5,7
Power supply of the unit	V/Hz	1 ~ 230/50-60		1 ~ 230/50-60		1 ~ 230/50-60		1 ~ 230/50-60		1 ~ 230/50-60		1 ~ 230/50-60	
Motor output	W	317	337	511	517	423	450	687	708	528	562	822	853
Motor current	A	2,14	2,24	3,37	3,3	2,85	2,99	4,53	4,52	3,57	3,73	5,42	5,45
Speed	rpm	1370	1360	1750	1650	1370	1360	1750	1670	1370	1360	1750	1610
Protection Class	IP	54		44		54		44		54		44	
Sales Code	-	WTN 234-832-040 WTN 234-832-042 WTN 234-832-044 WTN 234-832-046		WTN 234-832-048 WTN 234-832-050 WTN 234-832-052 WTN 234-832-054		WTN 234-832-056 WTN 234-832-058 WTN 234-832-060 WTN 234-832-062		WTN 234-832-064 WTN 234-832-066 WTN 234-832-068 WTN 234-832-070		WTN 234-832-072 WTN 234-832-074 WTN 234-832-076 WTN 234-832-078		WTN 234-832-080 WTN 234-832-082 WTN 234-832-084 WTN 234-832-086	

* Maximum air blowing distance at flow rate 3 m/s

** Sound pressure level at 3m, Q = 2

*** unit weight, without water

EC Declaration of Conformity – the current and full version of the EC Declaration of Conformity can be seen on our website www.xvent.cz under the Wind (category „hot air heating“) product documents

2.4. Technical data of water heaters

WIND-15A-ECV2-040

Input air temperature	Air flow	80/70				80/60				70/50				60/40				50/30			
		Heating performance	Supply air temperature	Water flow	Water pressure drop	Heating performance	Supply air temperature	Water flow	Water pressure drop	Heating performance	Supply air temperature	Water flow	Water pressure drop	Heating performance	Supply air temperature	Water flow	Water pressure drop	Heating performance	Supply air temperature	Water flow	Water pressure drop
°C	m ³ /h	MW	°C	m ³ /h	MPa	kWh	°C	m ³ /h	MPa	MW	°C	m ³ /h	MPa	MW	°C	m ³ /h	MPa	MW	°C	m ³ /h	MPa
0	6750	63,4	28,9	2,79	33	35,4	24,9	2,43	26	47,2	29,9	2,07	20	38,9	17	1,69	15	30,3	13,1	1,32	10
	3950	44,8	35,4	1,87	17	39,1	30,5	1,72	14	19,5	25,8	1,47	11	27,7	21	1,21	8	21,8	16,2	0,94	3
	1300	20,5	49,6	0,9	4	18,1	43	0,8	4	15,7	36,4	0,69	3	13,1	29,8	0,57	2	10,4	23,2	0,45	1
5	6750	58,9	32,2	2,59	29	50,9	28,1	2,34	23	42,7	24,2	1,87	17	34,4	20,2	1,5	12	25,9	16,3	1,12	7
	3950	40,5	38,2	1,83	15	38	33,4	1,58	12	30,4	28,8	1,31	9	24,8	23,8	1,07	6	18,8	19	0,85	4
	1300	19,1	51,5	0,84	4	16,7	44,9	0,73	3	14,3	38,3	0,62	2	11,7	31,7	0,51	2	8,98	25,1	0,39	1
10	6750	54,5	35,3	2,4	25	46,5	31,3	2,08	19	48,4	27,6	1,68	14	30	23,4	1,31	9	21,5	19,5	0,93	5
	3950	35,8	43	1,69	11	32,8	36,2	1,45	10	27,3	35,4	1,19	8	23,5	26,6	0,94	5	15,5	21,8	0,67	3
	1300	17,7	53,5	0,78	3	15,3	46,8	0,67	3	12,9	40,3	0,56	2	10,3	33,6	0,45	1	7,55	27	0,33	1
15	6750	50,1	38,5	2,21	22	42,1	34,5	1,85	16	34	30,6	1,49	11	25,7	26,6	1,12	7	17,3	22,6	0,74	3
	3950	35,4	43,9	1,56	11	29,9	39	1,15	9	24,2	34,2	1,06	6	18,4	29,4	0,8	4	12,4	24,5	0,54	2
	1300	16,8	55,4	0,72	3	14	48,8	0,61	2	11,5	42,1	0,5	2	8,85	35,5	0,39	1	6,09	28,8	0,26	1

the stated air flows correspond to the maximum, medium and minimum flow rates

WIND-15B-ECV2-040

Input air temperature	Air flow	80/70				80/60				70/50				60/40				50/30			
		Heating performance	Supply air temperature	Water flow	Water pressure drop	Heating performance	Supply air temperature	Water flow	Water pressure drop	Heating performance	Supply air temperature	Water flow	Water pressure drop	Heating performance	Supply air temperature	Water flow	Water pressure drop	Heating performance	Supply air temperature	Water flow	Water pressure drop
°C	m ³ /h	MW	°C	m ³ /h	MPa	kWh	°C	m ³ /h	MPa	MW	°C	m ³ /h	MPa	MW	°C	m ³ /h	MPa	MW	°C	m ³ /h	MPa
0	7800	69,3	27,2	3,05	37	60,5	23,4	2,66	30	51,6	19,7	2,26	24	42,4	16	1,85	17	31	12,1	1,43	13
	5200	51,6	37	2,36	24	46,9	27,6	2,06	20	40,1	21,2	1,75	25	31,1	18,9	1,44	11	25,9	14,6	1,12	10
	1950	27	44,8	1,19	8	23,8	38,6	1,04	6	20,5	32,6	0,9	6	17,1	26,7	0,75	6	11,6	20,7	0,59	4
5	7800	64,4	30,5	2,84	32	55,8	26,8	2,44	27	46,7	23	2,04	20	37,5	19,3	1,64	14	28,2	15,6	1,22	10
	5200	49,8	35	2,19	21	43,1	30,6	1,89	17	36,5	29,3	1,59	13	29,9	21,9	1,28	10	22,7	17,6	0,96	7
	1950	25,1	46,9	1,11	9	21,9	40,9	0,94	7	18,7	34,9	0,82	5	15,2	28,0	0,66	5	11,4	22,0	0,51	3
10	7800	59,6	33,9	2,62	29	50,8	30,1	2,23	23	41,9	26,4	1,83	16	32,7	22,6	1,41	12	23,3	18,9	1,05	8
	5200	44,1	38,1	2,01	19	39,4	33,7	1,73	14	32,6	29,3	1,43	12	25,6	24,9	1,12	9	18,4	20,6	0,8	5
	1950	23,3	48,1	1,03	7	20,1	43,1	0,88	6	16,8	37,1	0,74	6	13,4	31,3	0,58	4	9,73	25,1	0,42	4
15	7800	54,8	37,3	2,41	25	46	33,4	2,03	19	37,1	29,7	1,62	13	28	25,9	1,22	9	18,5	22,1	0,8	5
	5200	45,4	41,3	1,87	18	39,8	36,7	1,57	12	29	32,3	1,27	10	23,9	27,9	0,96	7	14,6	23,5	0,64	5
	1950	23,5	51,4	0,95	6	18,3	45,3	0,8	5	15	39,3	0,66	5	11,5	31,3	0,5	4	7,84	27,5	0,34	3

the stated air flows correspond to the maximum, medium and minimum flow rates

WIND-20A-ECV2-040

Input air temperature	Air flow	80/70				80/60				70/50				60/40				50/30			
		Heating performance	Supply air temperature	Water flow	Water pressure drop	Heating performance	Supply air temperature	Water flow	Water pressure drop	Heating performance	Supply air temperature	Water flow	Water pressure drop	Heating performance	Supply air temperature	Water flow	Water pressure drop	Heating performance	Supply air temperature	Water flow	Water pressure drop
°C	m ³ /h	MW	°C	m ³ /h	MPa	kWh	°C	m ³ /h	MPa	MW	°C	m ³ /h	MPa	MW	°C	m ³ /h	MPa	MW	°C	m ³ /h	MPa
0	8000	85,6	29,2	3,27	47	74,9	25,3	3,29	38	64	21,3	2,8	28	52,8	13,4	2,3	22	43,4	13,4	1,8	15
	5250	60	35,9	2,64	25	52,7	31,3	2,31	21	45,2	26,2	1,98	16	37,5	23,4	1,64	12	29,6	16,6	1,28	1,8
	1700	26,3	50,9	1,16	7	23,3	44,2	1,02	7	20,2	37,4	0,89	5	17	30,7	0,74	6	13,6	24,1	0,59	0,6
5	8000	79,3	32,5	3,51	41	68,9	28,5	3,03	33	58	24,5	2,54	26	46,9	20,6	2,04	18	35,4	16,6	1,54	11
	5250	55,8	38,7	2,46	23	48,5	33,9	2,13	18	41	29	1,8	14	33,1	24,2	1,45	11	25,4	19,4	1,1	9
	1700	24,5	52,8	1,08	7	23,8	46	0,95	6	18,4	39,3	0,81	5	15,1	32,6	0,66	5	11,7	25,9	0,51	3
10	8000	73,6	35,7	3,24	36	63	31,7	2,77	28	52,2	27,7	2,18	21	40,8	23,7	1,78	14	30,5	19,8	1,38	9
	5250	51,7	42,5	2,28	20	44,4	36,6	1,95	16	36,9	35,8	1,62	13	29,2	27	1,27	9	21,2	22,1	0,93	6
	1700	22,9	54,6	1,01	7	19,8	47,9	0,87	5	16,6	41,2	0,73	5	13,3	34,5	0,58	4	9,85	27,7	0,43	4
15	8000	67,7	38,9	2,96	31	57,1	34,9	2,51	25	46,2	30,9	2,02	17	35,1	26,9	1,53	13	23,5	21,9	1,02	7
	5250	47,6	44,1	2,1	17	40,3	39,4	1,77	13	32,8	34,6	1,44	11	25,1	29,7	1,09	8	17	24,8	0,78	6
	1700	21,1	56,5	0,93	6	18,2	49,7	0,79	4	14,8	43	0,65	4	11,5	36,3	0,5	3	7,99	29,4	0,35	3

the stated air flows correspond to the maximum, medium and minimum flow rates

WIND 208 ECV2-040

Input air temperature	Air flow	80/70				80/60				70/50				60/40				50/30			
		Heating performance	Supply air temperature	Water flow	Water pressure drop	Heating performance	Supply air temperature	Water flow	Water pressure drop	Heating performance	Supply air temperature	Water flow	Water pressure drop	Heating performance	Supply air temperature	Water flow	Water pressure drop	Heating performance	Supply air temperature	Water flow	Water pressure drop
°C	m ³ /h	kW	°C	m ³ /h	kPa	kW	°C	m ³ /h	kPa	kW	°C	m ³ /h	kPa	kW	°C	m ³ /h	kPa	kW	°C	m ³ /h	kPa
0	10400	89,6	22,8	4,13	34	81,9	21,8	3,8	45	69,9	20,1	3,06	34	52,8	18,1	2,51	26	45,1	17,8	1,96	17
	6900	72,1	22,5	3,18	25	63,2	20,3	2,78	28	54,1	19,7	2,17	21	44,8	18,3	1,95	17	35,2	16,9	1,53	13
	2600	36,1	45,1	5,8	11	33,1	39,1	3,41	10	27,7	33,1	3,21	8	23,1	37,1	3,01	7	18,4	21,1	0,8	5
5	10400	87,1	30,9	3,84	49	75,3	27,1	3,31	38	63,4	25,4	2,77	39	51,1	19,6	2,73	21	38,6	19,9	1,67	13
	6900	67	35,5	2,95	30	60,1	31,1	2,55	26	49,1	26,7	2,15	18	39,7	22,1	1,71	13	30,2	17,9	1,31	10
	2600	43,8	47,3	5,49	11	28,6	41,3	3,3	9	25,2	45,6	3,1	8	20,6	49,8	2,8	6	15,9	24,4	0,69	5
10	10400	80,8	34,2	3,55	42	68,8	30,5	3,03	33	56,9	26,7	2,49	25	44,6	22,9	1,94	17	32	19,2	1,39	11
	6900	62,1	38,5	2,74	27	53,2	34,1	2,34	22	44,1	29,7	1,93	18	34,8	25,1	1,52	12	25,1	20,9	1,09	8
	2600	31,4	48,4	1,98	10	27,7	44,6	1,59	8	22,7	47,6	0,99	7	18,1	51,5	0,79	5	14,3	29,5	0,58	4
15	10400	74,1	37,5	3,26	36	63,4	33,7	2,74	27	50,5	30	2,21	20	38,2	26,2	1,67	13	25,8	22,4	1,11	9
	6900	57,1	43,5	2,52	24	48,3	37,1	2,12	18	39,2	42,7	1,71	13	29,8	28,3	1,3	9	20,1	23,8	0,87	6
	2600	29	53,8	1,78	8	34,7	45,8	1,98	6	20,2	59,8	0,89	5	15,6	51,7	0,68	5	10,2	27,6	0,47	5

--the stated air flows correspond to the maximum, medium and minimum flow rates

WIND 25A ECV2-040

Input air temperature	Air flow	80/70				80/60				70/50				60/40				50/30			
		Heating performance	Supply air temperature	Water flow	Water pressure drop	Heating performance	Supply air temperature	Water flow	Water pressure drop	Heating performance	Supply air temperature	Water flow	Water pressure drop	Heating performance	Supply air temperature	Water flow	Water pressure drop	Heating performance	Supply air temperature	Water flow	Water pressure drop
°C	m ³ /h	kW	°C	m ³ /h	kPa	kW	°C	m ³ /h	kPa	kW	°C	m ³ /h	kPa	kW	°C	m ³ /h	kPa	kW	°C	m ³ /h	kPa
0	11250	107	29,2	4,7	31	93,4	25,2	4,1	25	79,7	21,2	3,49	20	65,6	17,2	2,86	15	51,3	13,3	2,23	11
	8750	74,8	35,9	3,79	17	67,6	31	2,89	14	54,2	26,1	2,46	12	46,2	21,1	2,01	8	36,6	16,5	1,55	6
	2150	33,1	50,7	3,46	6	29,1	43,9	1,79	5	25,4	47,2	1,11	5	21,3	50,5	0,81	4	17	23,8	0,74	4
5	11250	99,3	32,5	4,37	28	85,9	28,4	3,77	23	72,2	24,4	3,16	17	58,1	20,4	2,53	13	43,7	16,5	1,9	8
	8750	69,5	38,7	3,06	15	60,4	33,8	2,65	12	51	28,9	2,23	10	41,3	24,1	1,8	7	31,3	19,2	1,36	6
	2150	30,9	52,6	1,96	5	27,1	45,8	1,79	4	23,1	51,1	1,01	4	19	52,4	0,83	3	14,6	26,8	0,63	3
10	11250	88,8	35,7	4,05	24	78,4	31,6	3,45	19	64,7	27,6	2,81	14	50,8	23,6	2,21	10	36,1	18,8	1,58	8
	8750	64,4	41,5	2,84	13	55,3	36,6	2,43	11	45,8	31,7	2,01	8	36,1	29,8	1,58	6	26,1	22	1,13	4
	2150	29,7	54,4	1,27	5	34,9	47,7	1,09	5	20,9	41	0,91	4	16,7	54,2	0,73	4	12,3	27,5	0,53	2
15	11250	84,8	38,8	3,72	22	71,1	34,8	3,12	16	57,6	30,8	2,51	11	43,4	26,6	1,89	8	28,0	22,7	1,25	5
	8750	59,3	44,2	2,61	11	50,3	39,1	2,2	10	40,7	44,5	1,78	7	31	29,6	1,35	6	20,9	24,7	0,91	4
	2150	28,5	56,1	1,17	4	31,6	49,5	0,89	4	18,7	43,8	0,82	3	14,4	56	0,61	3	9,93	28,2	0,43	4

--the stated air flows correspond to the maximum, medium and minimum flow rates

WIND 25B ECV2-040

Input air temperature	Air flow	80/70				80/60				70/50				60/40				50/30			
		Heating performance	Supply air temperature	Water flow	Water pressure drop	Heating performance	Supply air temperature	Water flow	Water pressure drop	Heating performance	Supply air temperature	Water flow	Water pressure drop	Heating performance	Supply air temperature	Water flow	Water pressure drop	Heating performance	Supply air temperature	Water flow	Water pressure drop
°C	m ³ /h	kW	°C	m ³ /h	kPa	kW	°C	m ³ /h	kPa	kW	°C	m ³ /h	kPa	kW	°C	m ³ /h	kPa	kW	°C	m ³ /h	kPa
0	13000	117	27,5	5,15	17	101	25,7	4,48	10	87	20	3,81	24	71,8	16,2	3,12	17	55,8	12,5	2,42	13
	8650	90,1	32,4	3,97	14	78,9	28	3,47	10	67,5	23,6	2,95	15	55,7	19,2	2,43	12	43,6	14,8	1,89	8
	3750	45,5	45,1	7	8	40	39	1,76	6	34,5	33	1,51	7	28,7	27	1,25	5	22,8	21	0,99	4
5	13000	109	30,9	4,79	18	93,9	27,1	4,12	16	79,8	23,3	3,45	20	63,4	19,5	2,76	14	47,6	15,8	2,03	9
	8650	81,8	35,4	3,69	11	72,6	31	3,19	17	61,1	26,6	2,68	13	49,4	22,2	2,15	10	37,3	17,8	1,62	6
	3750	42,3	47,3	3,86	7	36,9	41,3	3,62	5	31,3	45,2	3,37	6	25,6	29,2	3,12	5	19,6	23,2	0,85	3
10	13000	100	34,2	4,61	28	85,7	30,8	3,76	23	70,7	26,8	3,2	18	55,3	22,8	2,45	12	39,5	19	1,72	7
	8650	77,6	38,4	3,42	19	66,4	34	2,82	14	54,9	29,6	2,6	12	41,1	25,1	1,88	8	31	20,7	1,35	6
	3750	39,2	46,5	1,73	6	33,8	43,5	1,49	6	28,2	37,4	1,24	5	22,4	31,4	0,98	4	16,4	25,3	0,71	4
15	13000	92,4	32,5	4,07	24	77,7	33,7	3,41	19	62,6	29,9	2,74	14	47,1	26,1	2,06	9	31,4	22,3	1,36	6
	8650	71,4	41,4	3,15	16	60,2	37	2,64	12	48,8	32,5	2,13	9	37	28,1	1,81	6	24,7	23,6	1,07	5
	3750	36,2	51,7	1,59	5	30,8	45,7	1,35	5	25,2	39,8	1,1	5	19,3	33,6	0,84	3	13,3	27,4	0,57	3

--the stated air flows correspond to the maximum, medium and minimum flow rates

- other technical parameters can be found in the catalogue sheet

3. Installation – installation of air curtains in the working position

3.1. General information, recommendations and safety during installation of the Wind air curtain

3.1.1. Electrical safety when installing the curtain



Before starting any assembly works, it is necessary to switch off the power supply to the prepared electrical installation for subsequent activation of the unit. During installation, the switch must be secured against being switched on again.

3.1.2. Modification of existing heating distribution systems

- It is appropriate to use filters for rough impurities in the heating systems to protect the water exchanger from possible damage from the existing distribution systems.

3.1.3. Load bearing capacity of the assembly site

- The selected assembly site must be suitable for the permanent load by the curtain. In case of doubt, the load capacity of the wall/walls must be verified by a structural engineer or other responsible person.

3.1.4. Minimum assembly distances

- The minimum intake distance (fan) of the curtain from the wall/ceiling is 0.3 m.
 - The minimum distance between the side of the curtain and the wall is 0.1 m (assess a suitable distance from the side of the exchanger outlets to allow easy connection).

- If this distance is not observed, the curtain may not work properly and the fans may be damaged or the noise of the unit may increase. The curtain exhaust must be set in such direction that there is no draft in the heated space, and, at the same time, for the best separation of spaces – to shield the inner space from the external influence. The air flow exiting the exhaust grid must not be directed directly to walls, beams, shelves, machines, etc.

3.1.5. Minimum safety distance from flammable substances



The minimum safety distance from flammable substances is at least 0.1 m from the side of the curtain (assess a suitable distance from the outlet of the exchangers due to easy connection) and 0.5 m in the direction of suction of the curtain. Adjust the distances according to the layout of the space.

3.1.6. Operation environment of the curtain

- The curtain must be located / operated in an inner dry space with temperatures range from 5°C to +40°C (the conditions must avoid water freezing in the exchanger – there is a risk of damage to the curtain) and non-condensing humidity corresponding to protection class IP 54 and IP 44, according to the selected type of curtain.

3.1.7. Levelling of the curtain



The curtain must be always levelled – with spirit level in the appropriate plane in which it is operated!

3.2. Ceiling installations

- The curtain must stand on a flat, coherent and solid surface.
- The correct height of the curtain must be at least 100 mm longer than the actual height of the curtained hole. If the height of the opening is greater than or equal to the height of the curtain, you must attach an additional curtain, see Point 3.3.

3.2.1. Positioning the curtain in the working position

- Place the unpacked curtain in its working position.
- Place it close to the hole that should be curtained in such a way that:
 - o The edge of the exhaust curtain closer to the wall must be flush with the door frame hole, at a minimum distance from the wall (see paragraphs 3.1.4. and 3.1.5.)
 - o Turn the curtain at 10° with the exhaust pointing out.

Curtain pre-blow setting - important for correct operation of the curtain



3.2.2. Fixing the curtain to the floor

- The curtain is fixed to the floor using the "WIND-HOLDER" (must be ordered as accessories).
- Screw the holder to the curtain with 6 screws M6x20 (a part of the packing of the "WIND-HOLDER").
- Mark the center of the drilled holes in the four grooves for anchoring to the floor. The centre of the drilled holes must be in the end positions of the anchoring grooves, for the possibility of increasing the curtain pre-blow (even greater turning of the curtain out). The holder installed in this way allows an increase of the pre-blow by up to 20°, i.e. the curtain may be rotated from 10° to 30°.
- Select suitable anchoring material and tools according to the floor material and type. Anchoring material is not part of the delivery.



The diameter of the anchoring material (clamps, bolts into dowels) must be 10 mm. A washer shall be placed under the head of the anchoring screws/nuts to better distribute the curtain weight.

- Screw the holder into the floor in such a way that the anchoring screws are in the end positions of the anchoring grooves for the subsequent possibility of increasing the pre-blow of the curtain. The curtain should be automatically rotated 10° outwards. Final fine-tuning – the curtain rotation is dealt with in point 3.7.
- Tighten the holder to the floor.

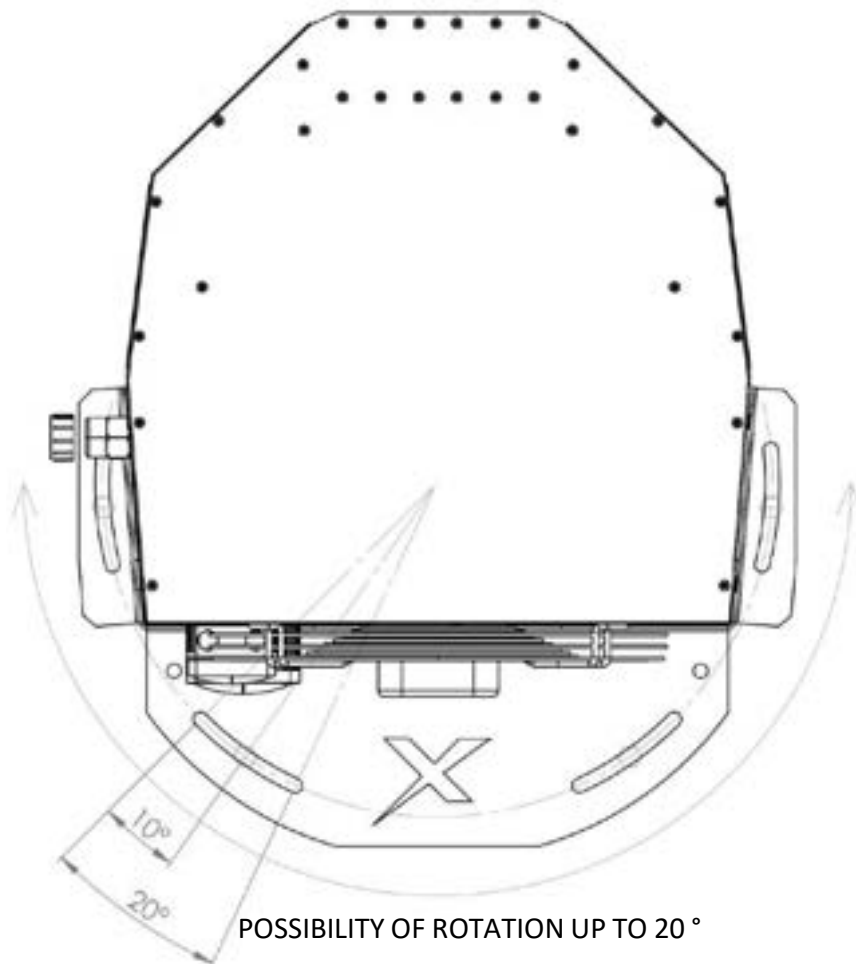

3.3. Vertical installation - curtain chaining

- Chaining – connecting the curtains to one another makes it possible to create an ideal assembly for proper clearance of the required opening according to its dimensions.
- The correct height of the chained assembly must be at least by 100 mm longer than the actual height of the construction opening.
- The curtains are chained on each other using the "WIND-CONNECT" connecting piece (it is necessary to order the pieces as accessories).

3.3.1. Chained curtain mounting

- Install the "WIND-CONNECT" connection piece onto the top of the anchored curtain, so that 1/2 of the connection piece projects over the anchored curtain. Use 6 screws M6x20 (part of the connection piece packing) to install the connection part.
- Lift up the curtain to be connected to the lower anchored curtain with appropriate lifting devices.



Ensure compliance with all safety principles resulting from handling the curtain to prevent any damage to the property and health of persons.

- Insert the curtain into the prepared /mounted connection piece and secure with 6 screws M6x20 (part of the fitting package).

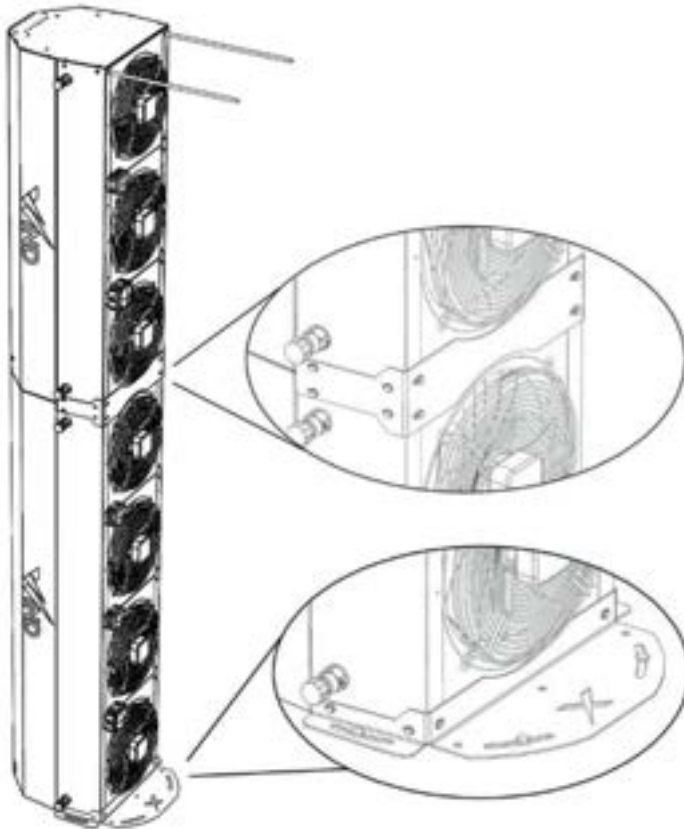

Use recommended accessories (WIND-CONNECT) to connect the curtain in case of chaining

Anchoring to the floor using a rotating holder (WIND-HOLDER) - not included in the packaging. Screwing in by using a suitable connecting material.

3.3.2. Side anchoring of the chained assembly

- When chaining multiple curtains, each subsequent curtain must be additionally anchored from the side to maintain the stability of the entire assembly.
- The side anchorage shall be made at the highest point of the chained assembly.
- Use the nuts M6 located at the side and at the curtain rear part (by the fan) to anchor the assembly from the side.
- Select a suitable method and connecting material for anchoring according to the situation at the place of installation

3.3.3. Maximum height of chained curtains

- **The maximum height of the chained assembly must not be greater than 6.5 m.**
- If the height of the assembly is higher than 6.5 m, it is necessary to select a method that creates a separate supporting element for supporting the subsequent curtains. The supporting element must be suitable to avoid loading of the lower-chained assembly by the top assembly so that it cannot be damaged or even cause damage to a property or endanger the health of persons.

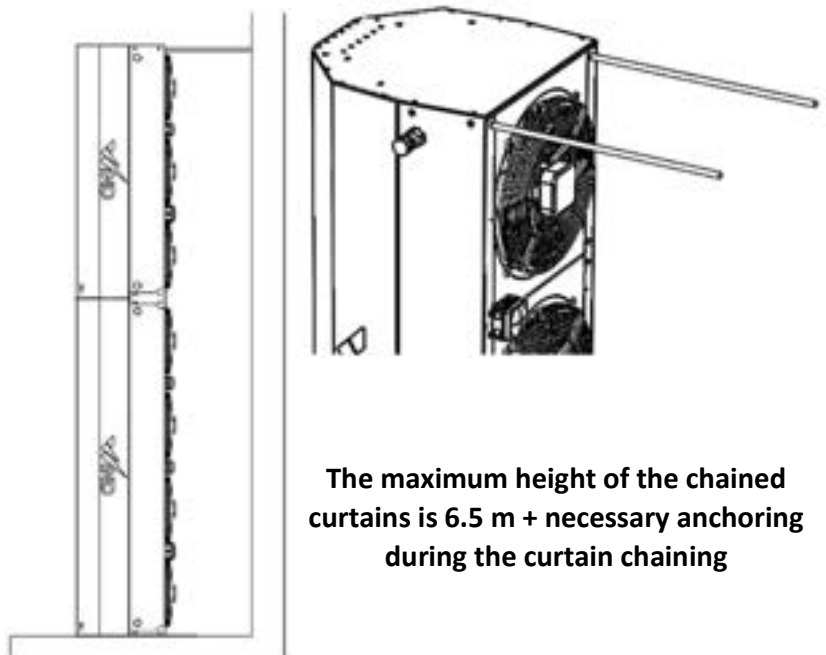

The maximum height of the chained curtains is 6.5 m + necessary anchoring during the curtain chaining

3.4. Vertical installation – increased barrier effect

- To increase the barrier effect, the curtain can be installed on both sides of the curtained opening (e.g. permanently open gates for loading and unloading trains)
- The curtains shall be installed in accordance with the same procedure as described in points 3.2 and 3.3.

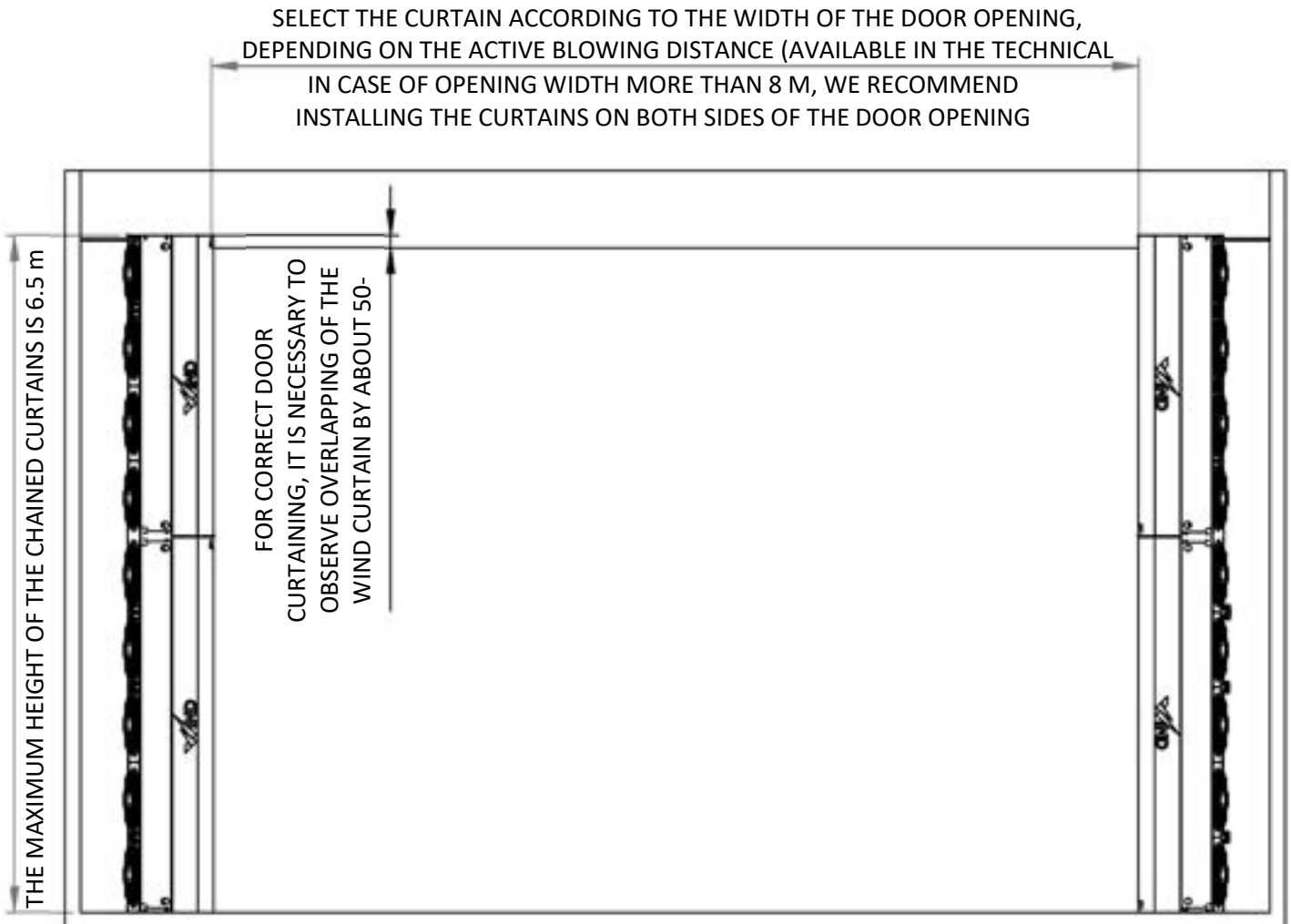

3.5. Horizontal installation



The surface (e.g. wall, brickwork) and auxiliary structures necessary to anchor the curtain must have an adequate load capacity based on the weight of the selected curtain type. Neither the anchoring material nor the auxiliary structures are provided by the supplier. The owner provides for himself/herself according to local conditions. See paragraph 3.5.2 for examples of installation.

- For the correct functionality of the curtain (curtaining the opening), the curtain must overlap on each side by at least 100 mm beyond the width of the curtained opening. If the width of the opening is greater than or equal to the length of the curtain, you should attach an additional curtain, see Point 3.6.

3.5.1. Preparation for the curtain suspension

- Unpack the curtain from the top of the curtain only (the curtain is delivered in the horizontal position), and proceed as follows:
 - o remove wooden battens,
 - o remove plastic packaging and tapes.



3.5.2. Determination of the installation site

- Determine the place for curtain installation; exhaust of the curtain must be flush with the door frame opening at the minimum distance from the wall (see 3.1.4. and 3.1.5.). If this is not possible, the general rule for correct positioning and subsequent turning of the curtain (pre-blow setting) applies, i.e. the exhaust corner of the curtain must always be at the tangent of the shielded opening. See paragraph 3.7 for further explanations.

3.5.3. Auxiliary anchoring structures

- Prepare suitable auxiliary anchoring structures (consoles, threaded rods, etc.) depending on the weight of the curtain, the surface into which you will anchor, and the selected suspension method (into the ceiling, in the wall, etc.).
- Wind air curtain weight table:

Series	Name	Weight of 1 screen
		kg
WIND-15	WIN1-15A-ECS0-0A0	42,8
	WIN1-15A-ECV2-0A0	54
	WIN1-15B-ECS0-0A0	44,4
	WIN1-15B-ECV2-0A0	56
WIND-20	WIN1-20A-ECS0-0A0	47,7
	WIN1-20A-ECV2-0A0	57,8
	WIN1-20B-ECS0-0A0	53,9
	WIN1-20B-ECV2-0A0	64
WIND-25	WIN1-25A-ECS0-0A0	71,1
	WIN1-25A-ECV2-0A0	83,5
	WIN1-25B-ECS0-0A0	78,6
	WIN1-25B-ECV2-0A0	91

3.5.4. Correct installation in horizontal position



To allow proper rotation of the curtain - 10° towards the outside area (pre-exhaust setting) - the total length of the hinge from the wall, on the far side of the wall, must be longer by 90 mm. The expected lateral distance of the curtain from the wall is 100 mm.

- If the distance from the wall is larger, the curtain must rotate at a larger angle, and the hinge length must be recalculated.
- To correctly determine the rotation angle of the curtain, the rule must be observed that the corner of the curtain exhaust must always be tangentially to the shielded opening.
- To facilitate suspension, we recommend using simple hangers (WIND-HINGE accessories), which are attached to the prepared threaded nuts on the side of the unit (use M6x20 screws).

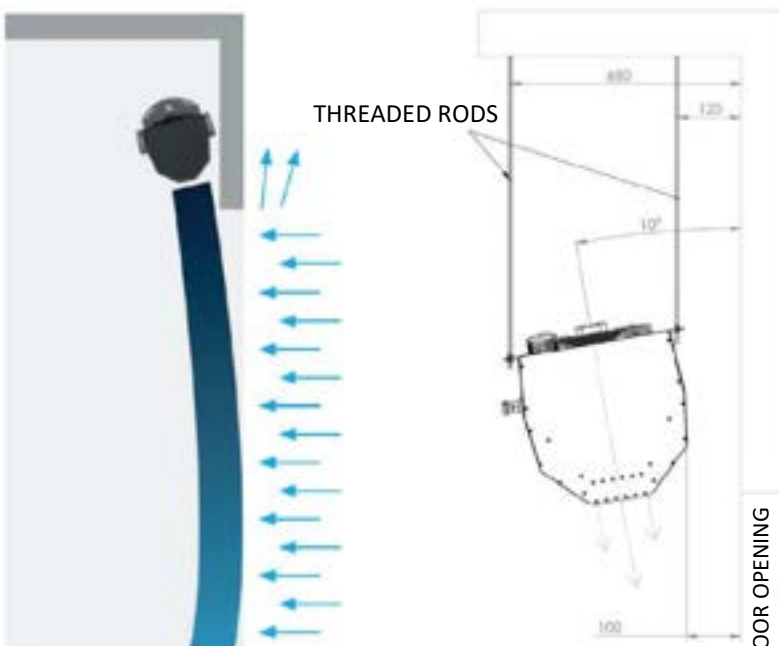

USE OF ASSEMBLY HINGES (ON EACH CURTAIN USE 4 HINGES) - WIND-HINGE accessories

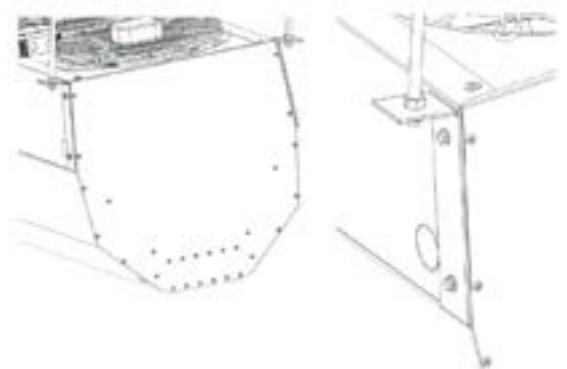

3.5.4.1. Examples of Curtain Suspension – Horizontal Installation

- Installation on the ceiling using the M8-10 threaded rods. Threaded rods M8-10 are not included in the delivery. It is ensured by the user according to local conditions.



- Installation on the wall using the wall console and threaded rods M8-10. Consoles and M8-10 threaded rods are not included in the delivery. It is ensured by the user according to local conditions.

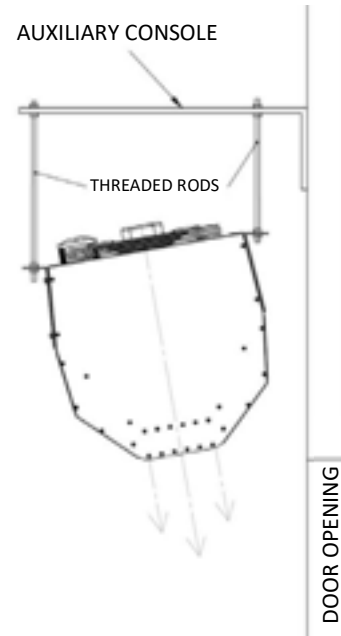

3.5.5. Measurement of anchoring holes

- Measure the anchoring holes according to the selected curtain type and anchoring type (according to the suspension layout) - see the main dimensions 2.2 - dimension D.

3.5.6. Installation of the auxiliary anchoring structure

- Install auxiliary anchoring structures, e.g.: wall consoles. Select suitable anchoring material and tools according to the material and the type of the background. Anchoring material is not part of the delivery.

3.5.7. Installation – hanging the curtain into the working position

- Lift the partially unpacked curtain according to section 3.5.1. with the installation hinges, using a suitable handling technique (e.g. a lift truck) to the prepared assembly point. Partial packaging (pallet, protective polystyrene) is used to protect the product from damage by scratching.

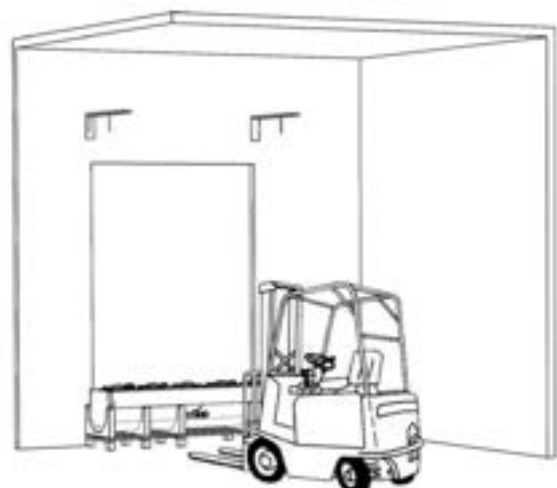
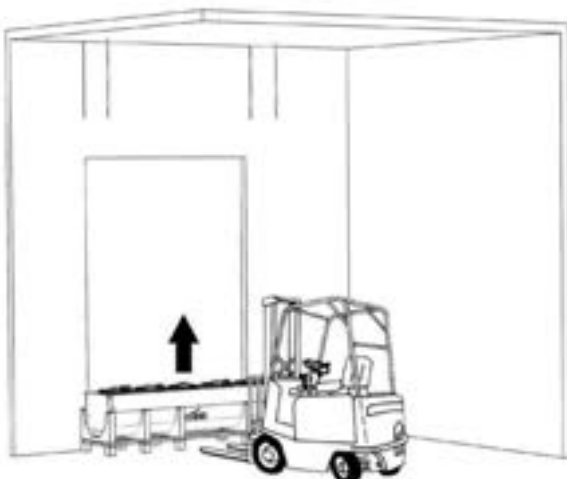



When handling the curtain, take into account its weight and ensure that all safety principles are observed so that no damage to the property or health of persons occurs.

- Secure the screw connections with the nuts against spontaneous unscrewing and subsequent fall.

3.6. Horizontal installation - curtain chaining



The curtains to be chained must not be connected before lifting them to the working position. Always handle only one curtain at a time, intended for chaining. The curtains will be connected to one another only after anchoring to the wall or the ceiling.

- By chaining – connecting the curtains side by side, it is possible to create an ideal assembly for proper curtaining of the particular opening, according to its dimensions.
- The correct length of the chained assembly must be at least by 100 mm longer from each side than the actual length of the curtained opening.
- The curtains are chained next to each other using the "WIND-CONNECT" connecting piece (it is necessary to order the pieces as accessories).
- The length of the chained curtain is not limited when installing the curtain in the horizontal plane.

3.6.1. Installation of the auxiliary anchoring structure

- Preparation for the curtain suspension according to section 3.5.1.

3.6.2. Determination of the installation location for the chained curtains

- Determine the place for the installation of the chained curtain; the exhaust curtain must be flush with the frame opening at the minimum distance from the wall (see 3.1.4. and 3.1.5.).
- When chaining the curtains, consider sufficient room for handling in the installation area.

3.6.3. Auxiliary anchoring structures for chained curtains

- Complete the auxiliary anchoring structure according to section 3.5.3. with respect to the weight of the chained assembly.



2 pcs of auxiliary anchoring structures per 1 piece of curtain must always be used (e.g.: 3 pieces of curtains in a chain - there must be 6 pieces of auxiliary anchor structures).

3.6.4. Correct installation in horizontal position during curtain chaining



For proper rotation of the curtain, i.e. 10° towards the outside area (blowing distance adjustment), the total length of the hinge at the more distant side must be 90 mm from the wall. The expected lateral distance of the curtain from the wall is 100 mm.

- If the distance from the wall is larger, the curtain must rotate at a larger angle, and the hinge length must be recalculated.
- To correctly determine the rotation angle of the curtain, the rule must be observed that the corner of the curtain exhaust must always be tangentially to the shielded opening.

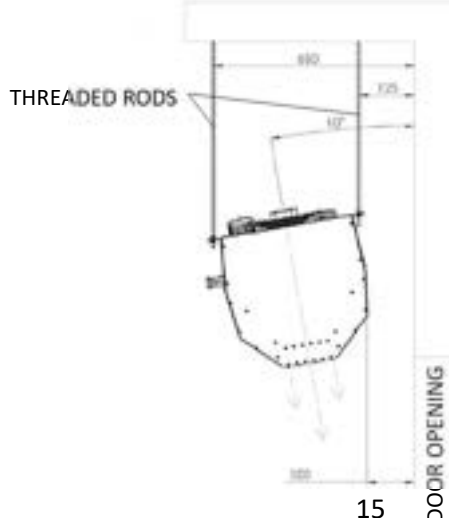
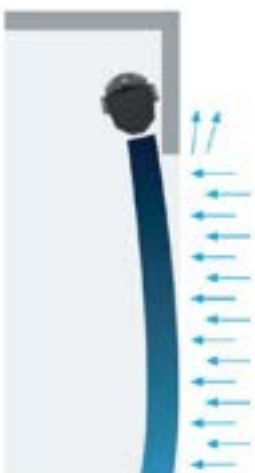

USE OF ASSEMBLY HINGES (ON EACH CURTAIN USE 4 HINGES) - WIND-HINGE accessories

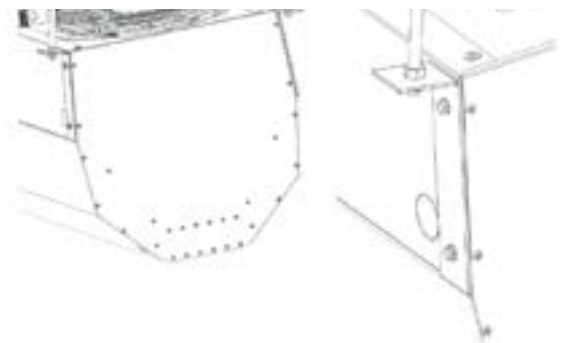

- To facilitate suspension, we recommend using simple hinges (WIND-HINGE accessories), which are attached to the prepared threaded nuts on the side of the curtain (use M6x20 screws). Use it also in case of mounting via "WIND-CONNECT" connecting piece

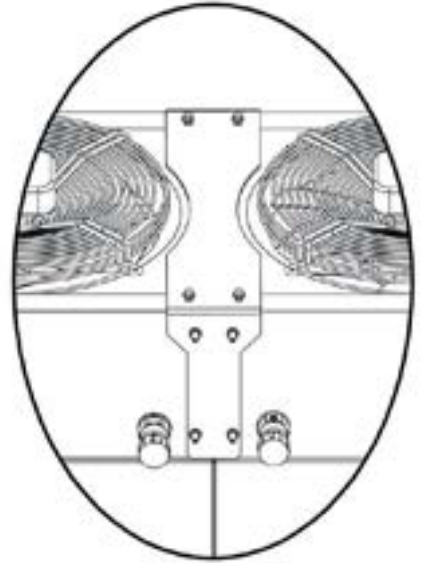

- Install the "WIND-CONNECT" connecting piece onto the side of the first chained curtain, so that 1/2 of the connecting piece protrudes from the chained curtain. Use 6 screws M6x20 (part of the connecting part packing) to install the connection piece.



Chained curtains must not be connected before lifting them to the working position. Always handle only one curtain at a time, intended for chaining. The curtains will be connected only after anchoring it to the wall or the ceiling.

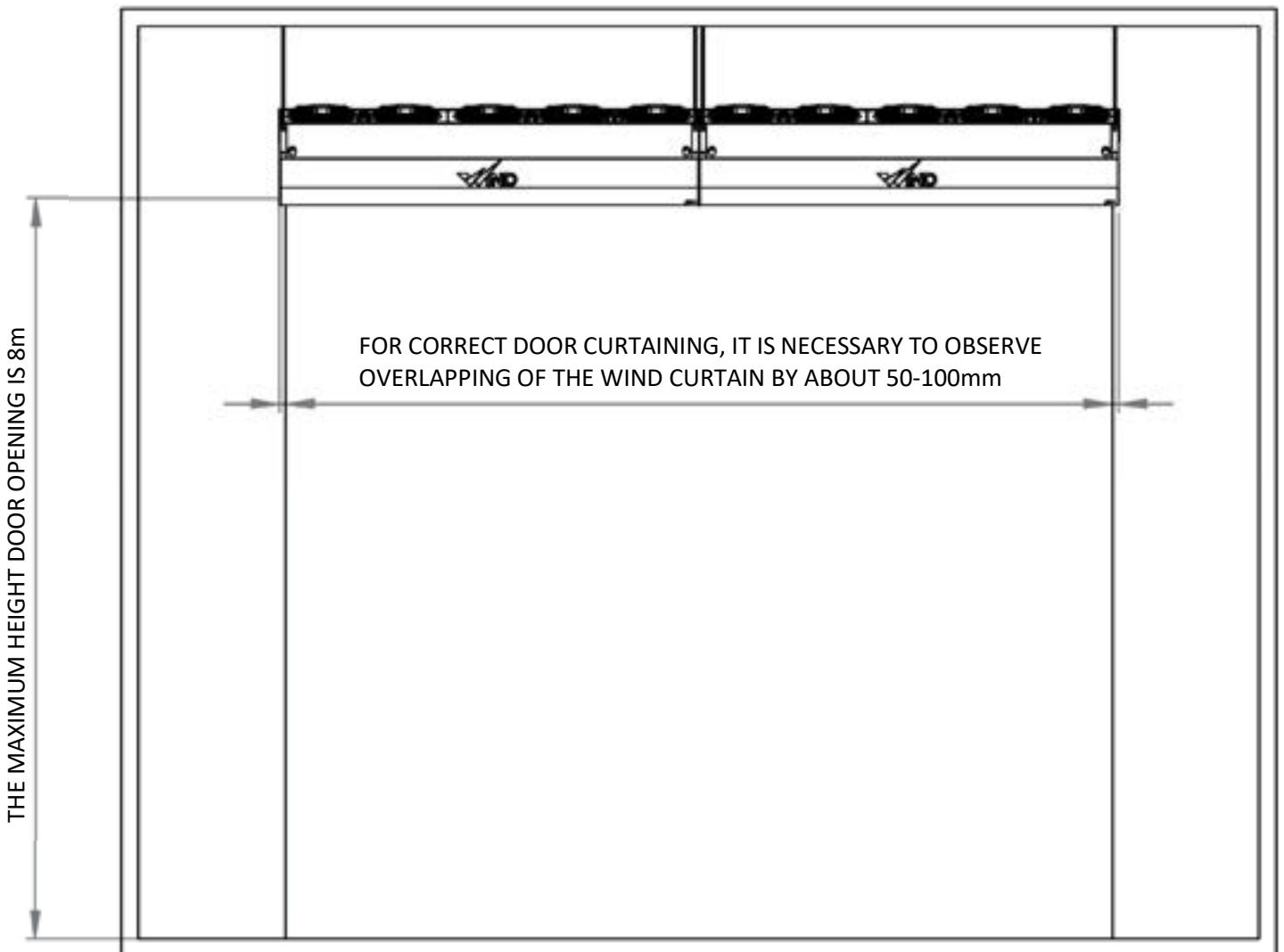

ASSEMBLY ILLUSTRATION - CHAINING OF CURTAINS + DISTANCE CONDITIONS

3.6.4.1. Examples of curtain suspension - horizontal installation – chaining

- Installation on the ceiling using the M8-10 threaded rods. Threaded rods M8-10 are not included in the delivery. It is ensured by the user according to local conditions.
- Installation on the wall using the wall console and threaded rods M8-10. Consoles and M8-10 threaded rods are not included in the delivery. It is ensured by the user according to local conditions.

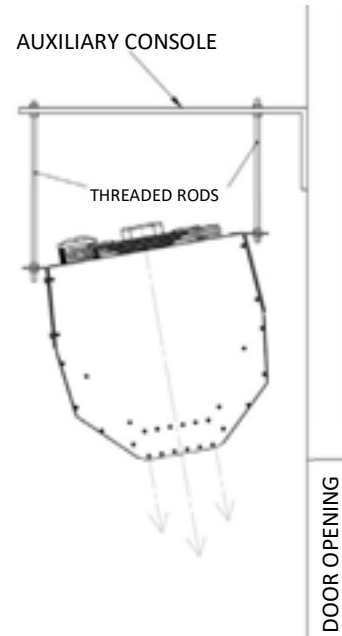

3.6.5. Measurement of anchoring holes for chained curtains

- Measure the anchoring holes according to the selected type of chained curtains and anchoring type (according to the placement of hinges) - see the main dimensions 2.2 - dimension D

3.6.6. Installation – suspension of the chained curtains into the working position

- Lift the partially unpacked curtain according to section 3.5.1. with mounted mounting hinges using a suitable handling technique (e.g. forklift) to the prepared assembly point. Partial packaging (pallet, protective polystyrene) is used to protect the product from damage by scratching. Then continue in chaining according to the instructions, see 3.6.4

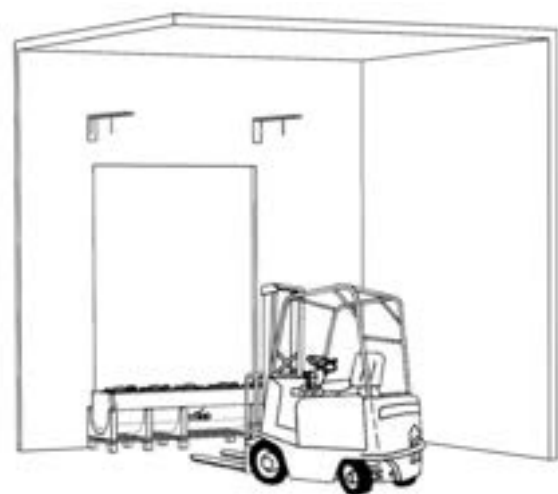
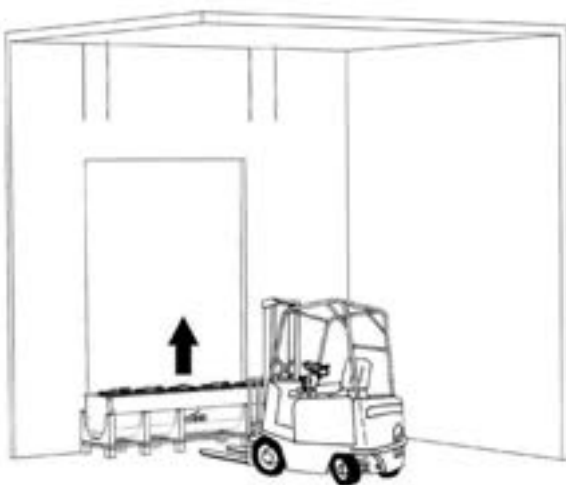

3.7. Installation – suspension of the chained curtains into the working position



Measure the anchoring holes according to the selected type of chained curtains and anchoring type (according to the suspension layout) - see the main dimensions 2.2 - dimension D

- Setting the correct curtain pre-blow is the basic prerequisite for proper separation between the interior and the outer space.
- At the curtain, the pre-blow is adjusted by turning the entire curtain. Pre-blowing adjustment using the lamellas is not possible.
- Minimum – the basic pre-blow angle is 10°.

3.7.1 Curtain rotation – vertical installation

- Curtain rotation – increase of pre-blow at a vertical installation allows the installed stand to be mounted within the range of 0 to 20°, so the maximum angle of the curtain turning towards the opening (direction out) is 30°.

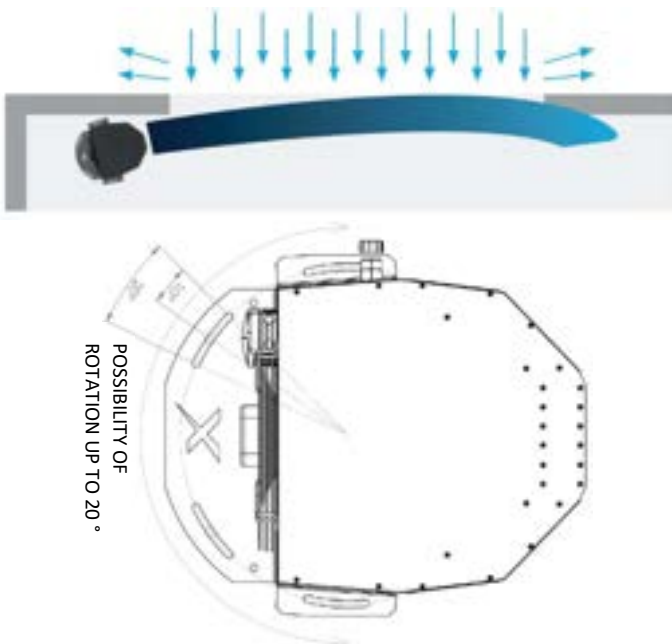

3.7.2 Curtain rotation – horizontal installation

- The curtain rotation – it is possible to increase the pre-blowing of the horizontal installation by unscrewing or extending the threaded bars on the brackets.

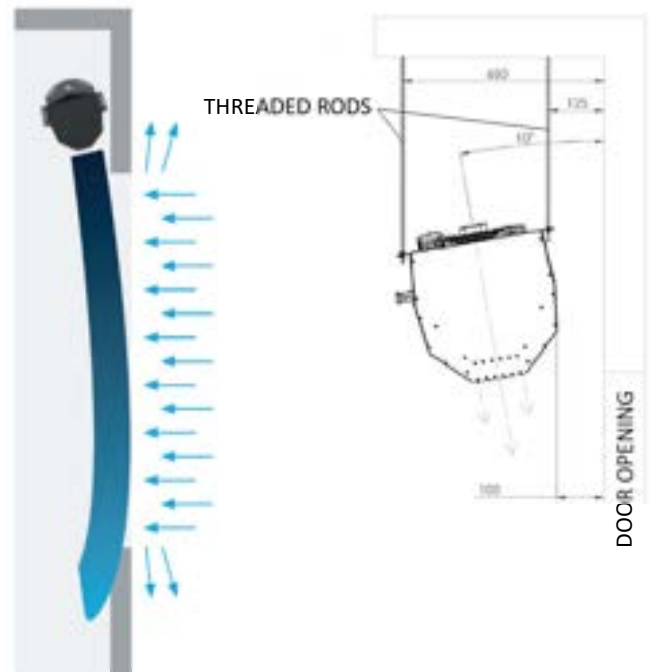

3.8. Water exchanger connection

3.8.1. Connection of the curtain to the hot water distribution system

- connect the curtain to the heating system using a flexible connecting piece with diameter 1" (e.g. Flexo hose with braiding – armoured hose). The flexible connection must be long enough to allow the pre-blow to be adjusted after commissioning.

3.8.2. Water exchanger connection

- Water supply and drainage necks are marked on the water exchanger collectors. To tighten the connected piping to the curtain, use the hexagonal profile on the water exchanger necks. This prevents the exchanger outlet from being overturned, which may result in irreversible damage to the water exchanger.



- After connecting the water exchanger to the heating system, a pressure test of the connected curtain is recommended.
- **The tests must be carried out by a person qualified in this field with knowledge of the applicable regulations and standards of the country concerned.**
- We recommend installing shut-off valves on the water exchanger inlet and outlet for the shut-off of the heating medium, or to allow the curtain dis-assembly without the need to drain water from the heating system.

3.8.3. Venting (discharge) valve

- Water exchangers are fitted with venting screws on the inlet and drainage collectors.
- Venting of the exchanger is done by loosening the vent screw.

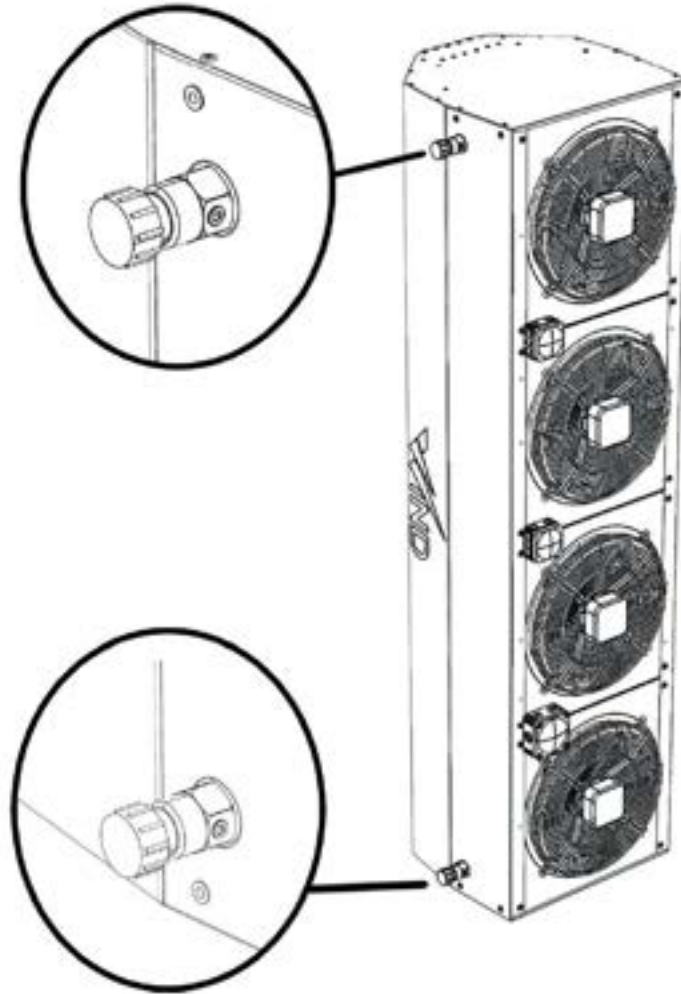

3.8.4. Example hydraulic diagram of unit connection

Legend:

1. Wind
2. speed regulator with thermostat
3. vent valve - part of the exchanger
4. flexible hose
5. shut-off valve
6. 2-way valve with thermoelectric drive
7. filter
8. pump
9. source of hot water

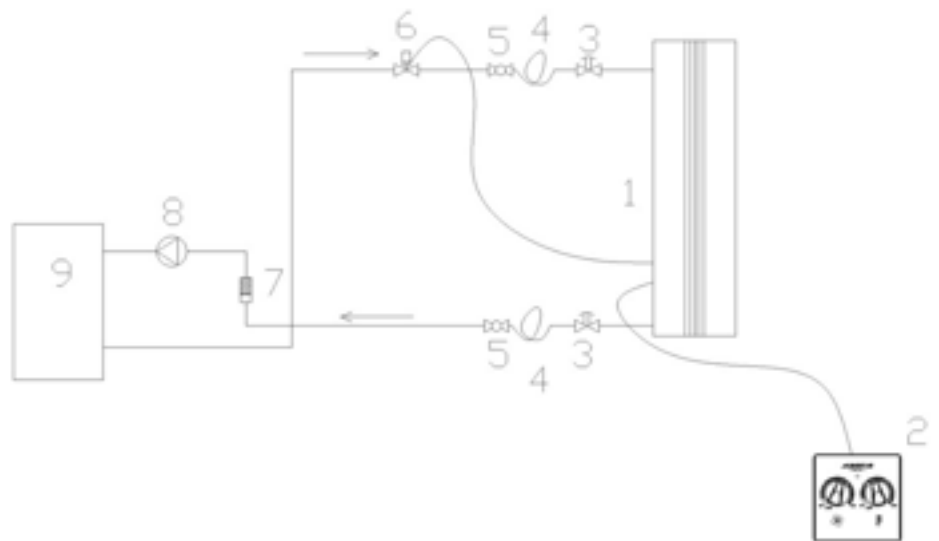

- If the automatic control valve is not installed to control the heating capacity, we recommend to shut off the heating water supply to the exchanger when the fan is switched off. Any high temperature inside the unit on the exchanger may reduce the fan lifespan.

3.9. Electrical installation and electrical connection

3.9.1. General Information - Safety



The relevant electrical installation and electrical assembly of the units may only be performed by persons qualified for this activity with valid authorization and knowledge of the applicable standards and directives. Before starting any assembly works, it is necessary to switch off the power supply to the prepared electrical installation for subsequent activation of the unit. During installation, the switch must be secured against being switched on again by an unauthorized person.

- The curtain shall be connected to the main power supply by the TN-S system (neutral wire connected) using an insulated cable in accordance with the diameter and corresponding regulations.
- The electrical installation and connection must be carried out on the basis of the electrical project proposed by a professional designer.
- Electrical diagrams on the product have higher priority than the diagrams in this manual!
- The supply voltage of the curtain shall be connected in such a way that all poles of the network are disconnected from the power supply by one element (e.g. main switch). The unit inlet phase must be connected via a protective power circuit breaker (protective switch) according to the corresponding current. The minimum distance between the disconnected contacts must be greater than 3mm.
- Before installation, check that the cable marking corresponds to the electrical diagram. If you have any doubts, please contact your supplier.

3.9.2. Connection of power supply and curtain control

- The curtain is equipped with a wiring box containing spring terminals of the push-in type for connecting the curtain power supply and control, membrane bushings for pulling the control cable through and a threaded bushing for connecting the curtain power supply (this bushing is intended only for the power supply cable).
- For correct installation of the curtain power cable, choose a free opening in the electrical installation box, into which screw the M20x1.5 threaded plastic bushing (part of the delivery).
 - o First, screw in the bushing slightly with your hand
 - o After the resistance of bushing against turning has increased, use a flat wrench size 24
 - o The bushing itself cuts through the opening in the wiring box, pushing out the cut-out section of the box (a wheel)
- The bushing can accommodate cables with diameters 6 to 13 mm.
- Pull the supply cable through the installed bushing and tighten it with a flat wrench size 24.



The correct installation of the bushing and its correct tightening also serve as a protection against pulling and tearing of the power cable

- Use the remaining membrane bushings at your discretion to install the control cable correctly.
 - o Pierce the bushing membrane with a screwdriver
 - o Pull through the control cable

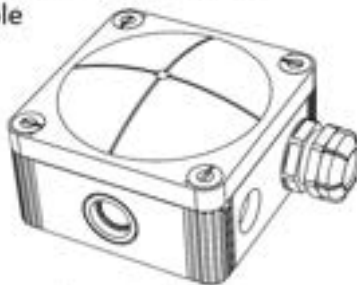

- Strip the cable insulation to a minimum length of 90 mm
- Strip the individual wires in the length of 10 mm. In the case of strand-type conductors, an insulated end piece must be pressed on (tube)
- Spring terminals are equipped with manual locking of wires. Strand-type conductors provided with pressed end (tube) may be installed in the terminals as well as solid conductors (wire) with cross section range from 0.2 to 1.5 mm². To connect the wire to the terminals, press the wire with a reasonable force and then slightly pull back to ensure that the wire is properly secured.

- If it is necessary to remove the wire from the terminal, press the orange locking button located on the terminal using a suitable tool and then pull the wire out of the terminal accordingly.
- The optimum cross-section of the conductor must be selected according to the actual length of the conductor route; however, the cross-section of the conductor may be max. 1,5 mm².



All wires must be connected to terminals with a reasonable force to prevent their damage. Stripping of cables to individual conductors should be 10mm. In the case of strand-type conductors, an end piece must be pressed on (tube).

- Table with minimum cable cross sections

air curtain type	number of conductors x conductor cross section in mm ²		recommended types of controls
	power supply	recommended control	
WIN1-15A	3 x 1	2 x 0,75	ELEMETAIR-E-M1
WIN1-15B	3 x 1	2 x 0,75	ELEMETAIR-E-M1
WIN1-20A	3 x 1	2 x 0,75	ELEMETAIR-E-M1
WIN1-20B	3 x 1	2 x 0,75	ELEMETAIR-E-M1
WIN1-25A	3 x 1	2 x 0,75	ELEMETAIR-E-M1
WIN1-25B	3 x 1	2 x 0,75	ELEMETAIR-E-M1

3.9.3. Description of power and control terminals – electrical diagram of motors

3.9.3.1. Description of connection of 1 curtain

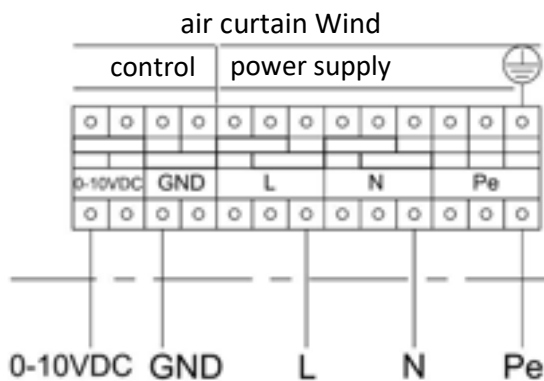

Clamps intended for power supply

- Terminal marked as L – supply phase.
- Terminal marked as N – neutral conductor.
- Green-yellow terminal marked as Pe – grounding wire
- Terminals intended for control
- Terminal marked as PWM/0-10V – input control signal 0-10V
- Terminal marked GND – input special grounding wire to the fan control signal. It shall not be used otherwise than to control the fan.

3.9.3.2. Description of the curtain connection during the chaining

- Connect the curtains during the chaining according to the diagram, see point 5.3.
- The connecting terminals allow inter-connection of the chained curtains. However, up to a maximum total current 15 A of the entire chain assembly, and the maximum cross-section of the conductors of 1.5 mm².



The earthing conductor must be connected separately. It is not possible to chain through the connecting terminals.

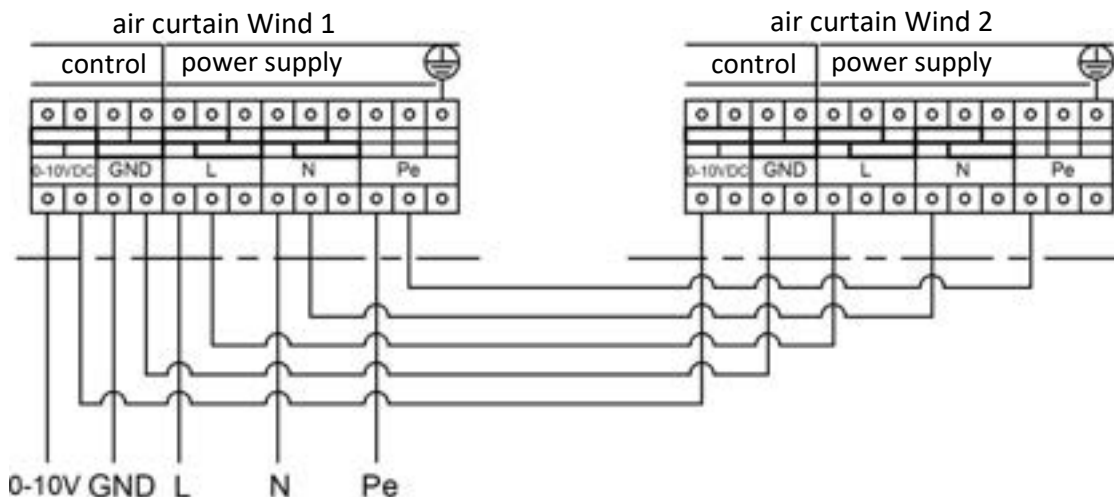

 The connection of the power supply and control terminals must be carried out in such a way that they cannot be either inter-connected nor switched among each other. This would result in the destruction of the unit fan and possible further damage to the property and health of persons.

3.9.4. Connection to the mains

 The relevant electrical installation and electrical assembly of the curtains may be carried out only by persons qualified for this activity with valid authorization and knowledge of the applicable standards and directives. Before starting any assembly works, it is necessary to switch off the power supply to the prepared electrical installation for subsequent activation of the curtain. During installation, the switch must be secured against being switched on again by an unauthorized person.

3.9.5. Display of electrical parameters on the curtain

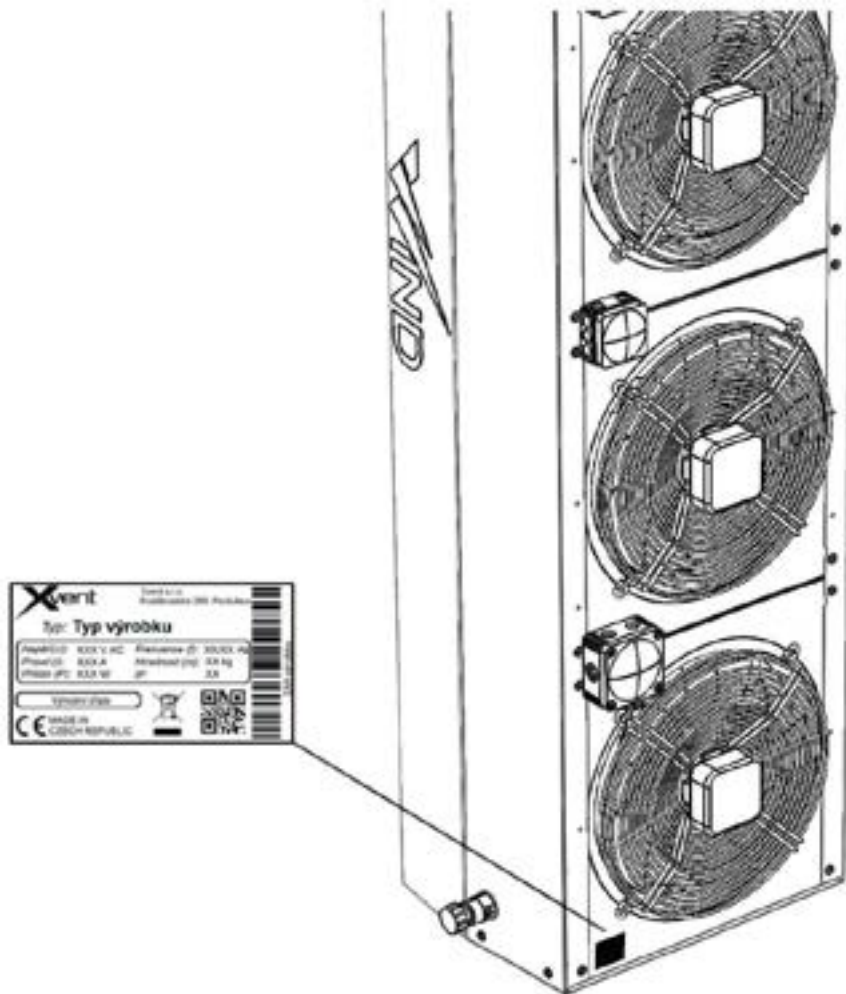

4. Regulation

4.1. General Information – Safety

 Electrical connection of control elements may only be carried out by persons qualified for this activity with valid authorization and knowledge of the relevant standards and directives. Before starting any assembly work, it is necessary to switch off the power supply. During installation, the switch must be secured against being switched on again by an unauthorized person.

- Before starting the installation of the control elements and connecting the installation, it is necessary to familiarize yourself with the original documentation of the individual elements

4.2. Control elements

name / sales code	illustration of control element	technical data			Comments
		description of the variables	units	value	
Speed and temperature regulator ELEMENTAIR-E-M1		Regulator input voltage	V/Hz	1 ~ 230/50-60	<ul style="list-style-type: none"> - Up to 25 fans can be connected to one regulator, regardless of the type of screens - Number of fans in 1 screen: Screen type number of fans WIN1-15X-ECXX 3pcs WIN1-20X-ECXX 4pcs WIN1-25X-ECXX 5pcs - Description of individual regulator functionalities described in a separate catalog
		Max. current carrying capacity	A	5	
		Max. loading capacity for valve servo control	A	5	
		Output signal for fan control	VDC	0-10	
		Permissible load (for EC variant 0-10)	A	0,02	
		Temperature control range of the room thermostat	°C	5 - 35	
		Temperature sensor	-	integrated	
		Protection type	-	IP20	
		Net weight	kg	0,16	
		Magnetic contact B-3		Maximum switched voltage	
Maximum switched current	A			0,4	
Contact closing distance, mounting distance	mm			38	
Contact disconnection distance	mm			42	
Contact type	-			NC (normally close)	
Operating temperature range	°C			-10 a1 +55	
Maximum relative humidity	%			90	
Dimensions of the magnet cover	mm			50x17x9,8	
Cable length / conductor cross-section	mm/mm ²			680 / 0,5	
Net weight	kg			0,07	
Valve + actuator (servo-unit) MTA-230-NC + V2050CH020		Power supply	V/Hz	230/50 - 60	<ul style="list-style-type: none"> - we recommend to attach the assembly on the return pipe - the servo-unit is controlled by a room thermostat from the ELEMENTAIR-E-M1 regulator - we recommend connecting the servo-unit with a cable with a cross-section of 2 x 0.75 mm²
		Consumption	W	2	
		Connection dimension	"	3/4	
		Max. medium temperature	°C	120	
		Max. ambient temperature	°C	50	
		Protection class - in any position	-	IP 44	
		Net weight	kg	0,3	
Filter FILTER-350		Filtration Class	-	G2 (ISO Coarse)	- filter with installation set for installation on the screen - fan
		Net weight	kg	0,1	
Base WIND-HOLDER		Net weight	kg	2,8	<ul style="list-style-type: none"> - the base is suitable for all Wind curtain - the base is used to attach the curtain in a vertical position to the floor
		Dimensions (height x width x depth)	mm	60x610x400	
Connecting piece WIND-CONNECT		Net weight	kg	1,8	<ul style="list-style-type: none"> - the connecting piece is used to connect the chained screens - always choose the number of chained pieces according to the number of screens chained
		Dimensions (height x width x depth)	mm	120x540x140	
Hinge WIND-HINGE		Net weight	kg	0,8	<ul style="list-style-type: none"> - the hinge is used to hang the curtain - in the package of this accessory, there are 4 pcs of hinges + 8 pcs of M6x20 screws
		Dimensions (height x width x depth)	mm	300x250x50	

5. Atacama heating unit wiring diagram

5.1. Details of connecting the main terminal box to the regulator ELEMENTAIR-E-M1 and with the accessories

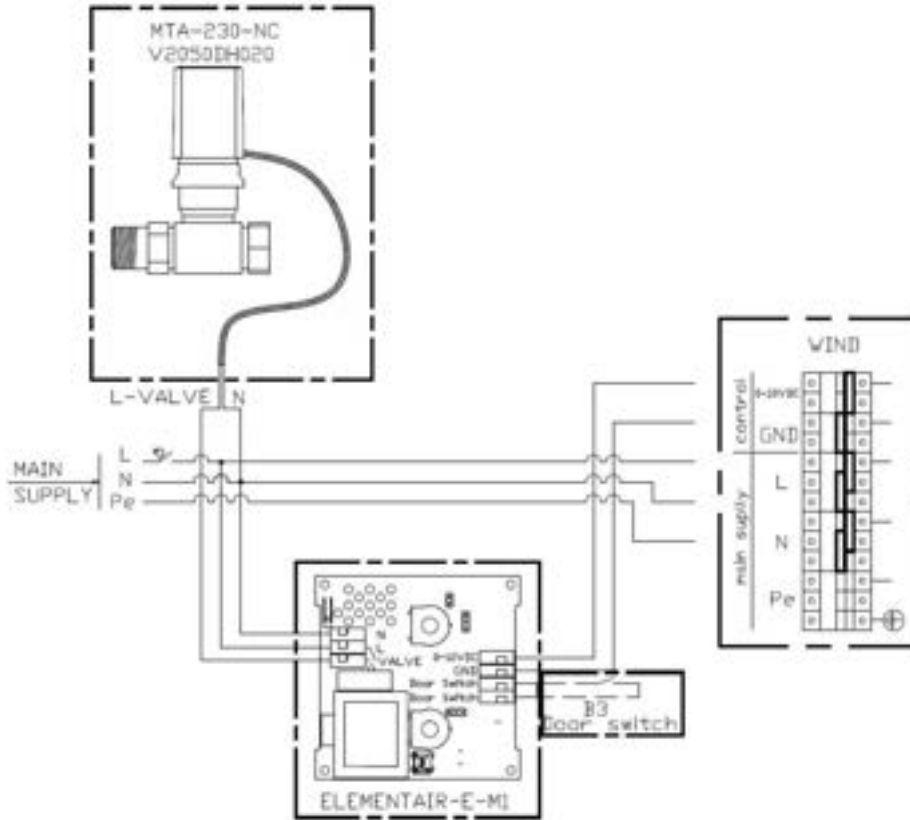

5.2. Connection of the Wind curtain with the regulator ELEMENTAIR-E-M1

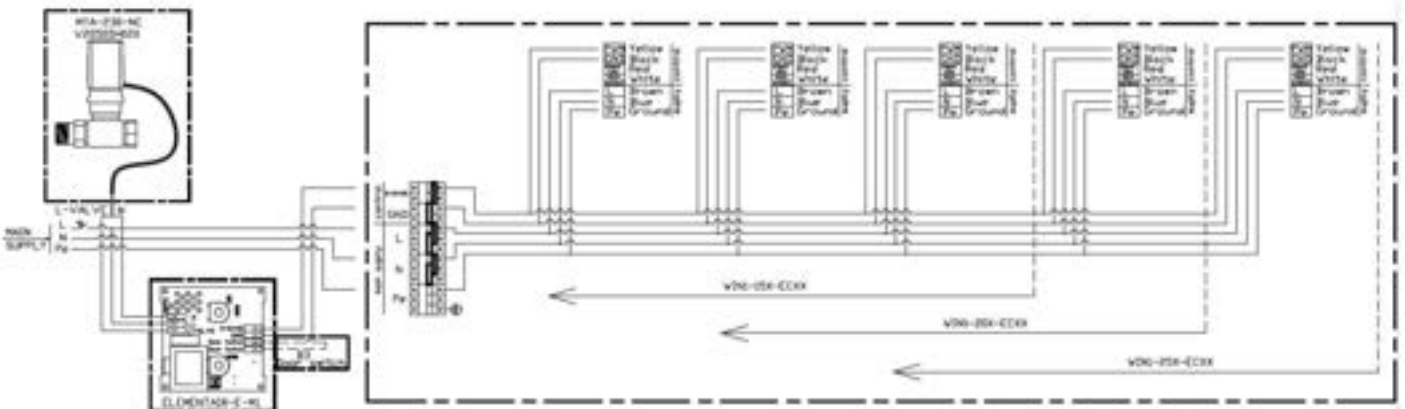

5.3. Connection of chained Wind curtains with regulator ELEMENTAIR-E-M1

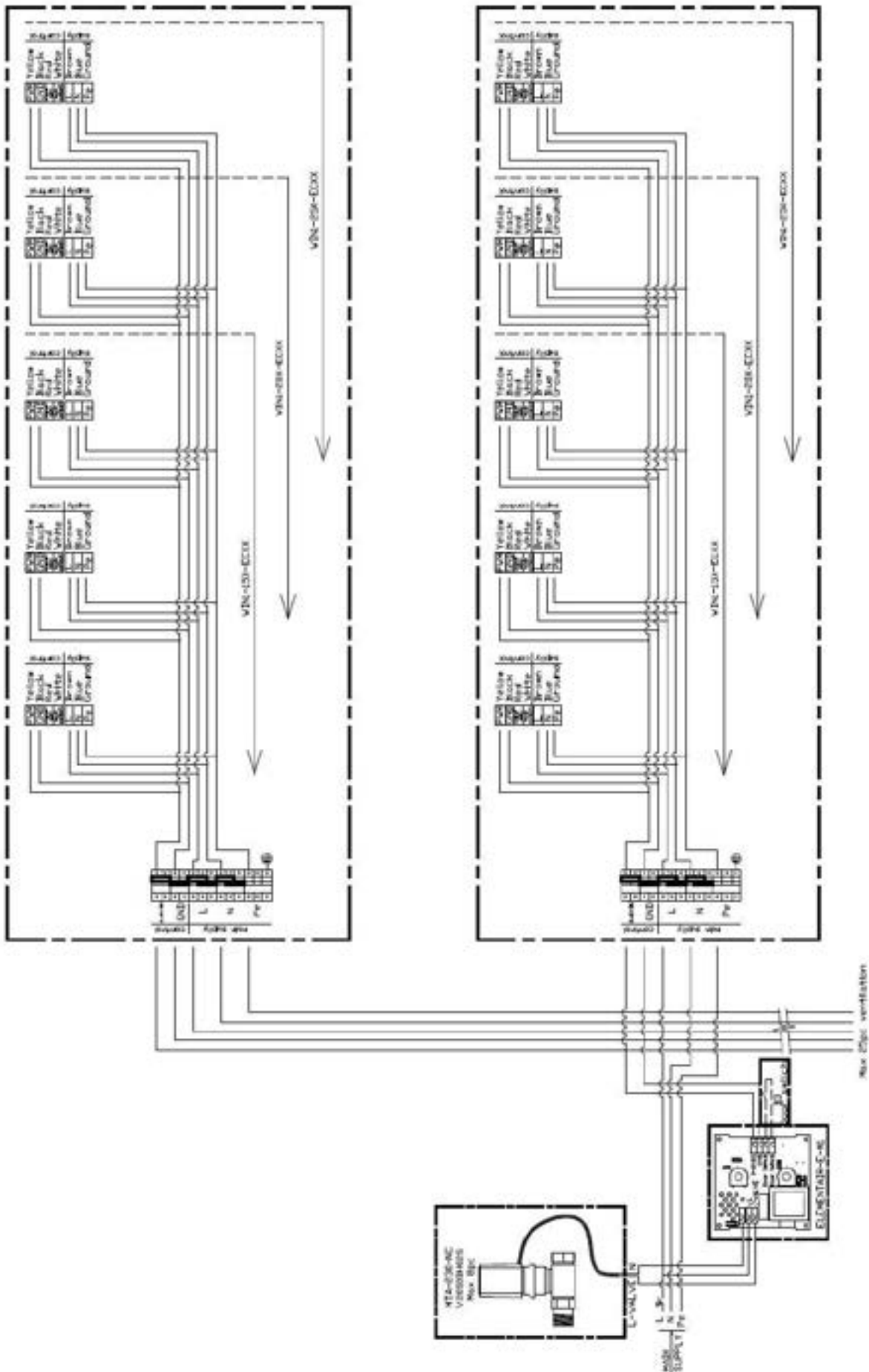

6. Commissioning

6.1. Before the first start check the following:

- If there are no objects in the curtain that could damage the unit (e.g. tools);
- If all the hydraulic connections are properly connected (tightness of the vent valve, connection branch and the mounted valve);
- If all electrical connections are connected correctly according to technical documentation, including connection of regulation and accessories;
- If the curtain has all the mounting and installation screws tightened.



All connections must be made in accordance with the technical documentation supplied to the unit and the documentation supplied to the control elements.

6.2. Switching on

- After the first start, check the basic functionality of the individual parts of the curtain (fan operation, heating), and also focus on the tightness of hydraulic system.
- Check the other functions of the entire assembly according to the instructions for use of the selected regulator.

7. Regular maintenance and cleaning of the WIND curtain



Before any maintenance and cleaning of the curtain, the unit must be disconnected from the power supply and the heating water supply to the curtain exchanger must be switched off. Work must be carried out only after the exchanger has cooled down. Otherwise, there is a risk of burns and injuries caused by rotating parts!!!

7.1. Regular maintenance

- Regular check of the curtain, especially the water exchanger, is recommended to perform every 500 hours of operation of the curtain.
- The curtain must also be checked before the start and at the end of the heating season.
- If the curtain is not used for a longer period of time, it is necessary to switch off the supply voltage to the curtain.
- If the temperature in the space is assumed to fall below 5°C and the temperature of the heating water is low, there is a risk of the heat exchanger freezing – bursting. Curtain – exchanger is not equipped with anti-freeze protection.
- Regular maintenance must include:
 - o Check of heat exchanger and clean it from dust and grease, if any.
 - o Check of the motor and fan (bearings), remove the dust and grease on the protective cage and fan blades.
 - o Check of tightening of all screw joints on the curtain (e.g. screws for fixation of the curtain on the console, mounting screws into the wall), including checking mechanical damage of the curtain (e.g. damaged fan cage)

7.2. Cleaning procedure

- **Compressed air, aggressive chemicals, water or sharp objects must not be used to clean the unit**
- Always wear protective gloves when cleaning the curtain
- The following tools are necessary to clean the curtain:
 - o Wrench of the appropriate size, according to the curtain
 - o Vacuum cleaner
 - o A lint-free cloth
 - o Brush
 - o Cleaning solution (soap water)

- Using an appropriate wrench, remove the fan from the unit rear plate.

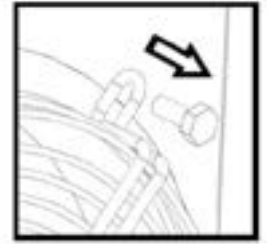
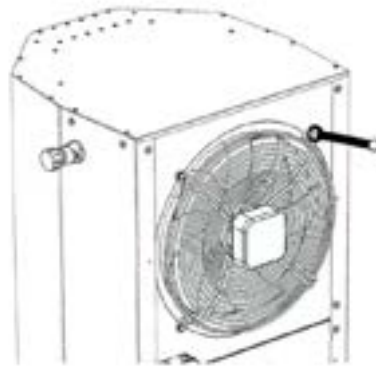
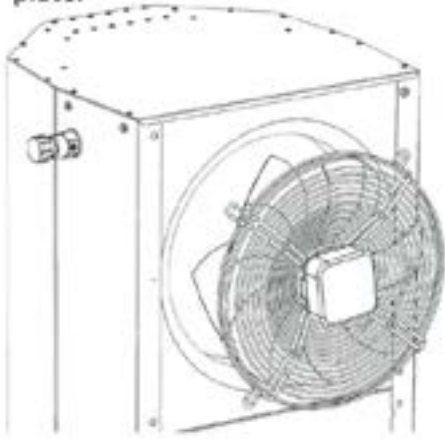

- Clean the fan with brush. Alternatively, wash with a cloth soaked with soap water.

- Clean the water exchanger and inner housing of the unit with the vacuum cleaner

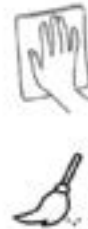
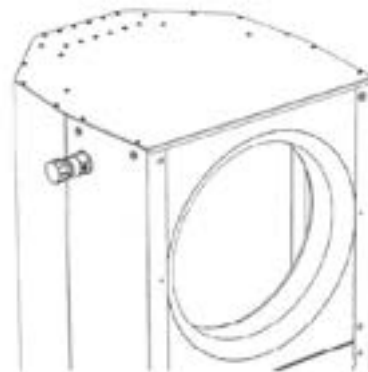
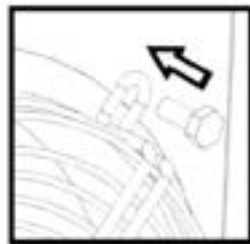
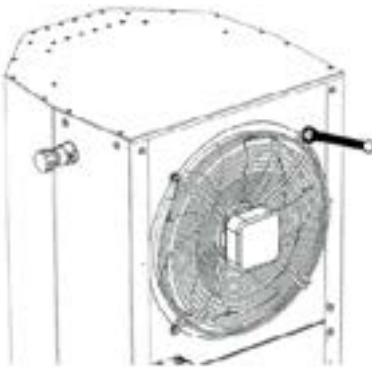

- Re-assemble the fan back into the rear plate of the unit. Make sure the fan is properly centred against the unit neck.

- Clean the water exchanger and inner housing of the unit with the vacuum cleaner

8. Service



Comply with the general country-specific provisions. In case of any service activity, it is necessary to disconnect the curtain from the mains and switch off the heating water supply to the curtain exchanger. Work must be carried out only after the exchanger has cooled down. Any electrical service work must be carried out by a person with professional qualifications. Complete the electrical connection precisely according to the supplied electrical documentation

8.1. Troubleshooting procedure

Failure	Possible cause of the fault	Troubleshooting
Leakage of the heating system, exchanger – dripping	Untightened heating system connections, vent valves	Tighten or reseal all leaking joints
	Heat exchanger rupture due to temperature drop below 0°C and insufficient heating water temperature	The heat exchanger is irreversibly destroyed, disconnect the unit from electricity and heating water. Contact the supplier.
Low heat output of the unit	The exchanger is aerated	Open the vent valve on the heat exchanger. See section 3.8.3
	The exchanger is heavily contaminated with dust and/or grease	Open the vent valve on the heat exchanger. See section 3.8.3
	Shut-off or control valves are not fully open	Check and, if necessary, open the shut-off valves. For the control valve, check its correct connection, functionality, or replace it with a new one
	Auxiliary filter clogged	Clean the filter or replace it – contact the supplier
The curtain is too noisy	The intake or exhaust space is blocked	Clean; release intake and exhaust
	Fan bearing noise, the fan rotates very hard	Fan replacement required – contact the supplier
	Auxiliary filter clogged	Clean the filter or replace it – contact the supplier
	Unbalanced fan – the fan vibrates extremely during operation	Fan replacement required – contact the supplier
The curtain works independently; after connection with the regulation it does not	Incorrect connection of the regulator with the curtain	Check the connection according to the recommended wiring diagram

9. Decommissioning and recycling



All unused or not operable products and packaging should be returned to the appropriate recycling locations where they will dispose of them in a professional manner. Please dispose the unusable parts of the product in a controlled landfill. Only like this the recycled product can be reused and bring a new benefit.



10. Warranty

We do not guarantee the suitability of using the regulator for special purposes; determination of suitability is fully within the competence of the customer and the designer. The regulator warranty is valid according to legal regulations. The warranty only applies if all installation and maintenance instructions are followed. The warranty covers manufacturing defects, defects in material or defects in the operation of the equipment.

The warranty does not apply to defects caused by:

- improper use or project
- incorrect handling
- during transport (damage caused by transport and its financial compensation must be resolved with the carrier)
- incorrect assembly
- incorrect electrical connection or protection
- incorrect operation
- by unprofessional intervention in the regulator
- wear and tear in a normal manner
- as a result of a natural disaster

When applying the warranty, it is necessary to submit a report (part of this document) containing:

- details of the complaining person/company
- date and number of the sales document
- detail defect description
- wiring diagram and protection data
- photo of the product's manufacturing label and, where appropriate, serial number
- photo from the place of product installation
- product measured values: air temperature, voltage, current

The method of handling the warranty repairs is carried out at the company service centre or at the place of installation. The method of resolving warranty repairs is exclusively at the discretion of the company's service centre. The complaining party shall receive a written statement on the result of the complaint – warranty repairs. In the event of an unjustified complaint, all costs associated with this shall be borne by the complaining Party.

11. Conclusion

If you have any doubts about this product, please do not hesitate to contact us.

Contact address:

SMART-FLEX Sp. z o.o.
Mielczarskiego 21/23
42-202 Częstochowa

