

The quick guide will guide you through the quick installation of the product, but it does not replace the complete full guide in any case. The complete operating instructions are available on our website www.xvent.cz or you can download them using the QR code. To read the QR code, use a smart device (mobile phone, tablet, etc.) that is equipped with this technology.



The installation and connection have to be performed only by authorised person and inline with safety law instructions valid in the area of the installation. All instructions in the operating and installation instructions must be observed during installation.



Purpose of using Xcont-HUB device

- The Xcont-Hub device (HUB) serves as an RS485 bus hub with MODBUS RTU protocol for XROOM, XHOUSE and XFLAT units, which are controlled by the superior BMS system (central unit).
- HUB is designed for indoor covered and dry areas with ambient temperature from + 5 ° C to + 40 ° C. With a maximum non-condensing relative humidity of 80%.
- The HUB working environment must comply with electrical protection IP 20.
- The HUB must not be operated in an environment with a risk of explosion or burning and increased dust. Especially during finishing construction activities, which cause excessive dust, eg: grinding concrete, plasterboard, etc.
- Neither the manufacturer nor the supplier is liable for damages caused by incorrect use of the HUB.

Main dimensions of Xcont-HUB

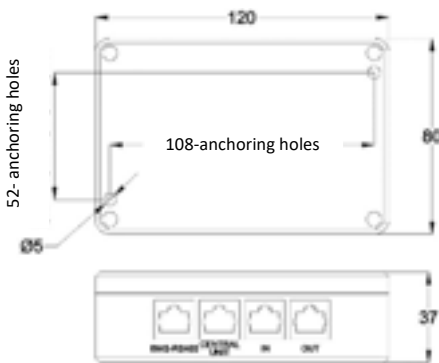

Installation of Xcont-HUB

- perform the installation using the anchoring holes hidden under the lid of the HUB box. Max diameter of anchor bolts 5mm.
- Always install the HUB on a solid surface to prevent it from being accidentally released and consequently damaged.
- We recommend that you always make the connection of the heat recovery unit controller with the HUB and the subsequent connection with the network cable in one piece. Avoid using network cable connectors - a possible source of faults.

Minimum distances

- the minimum distance from non-flammable substances is 50 mm.
- the minimum safety distance from flammable substances in all directions is 500 mm.

Modbus box connection - Xcont-HUB (socket BMS-RS485) with unit controller

- An Ethernet cable with RJ45 terminals with a direct connection is used to daisy-chain hubs or to connect heat recovery unit controllers

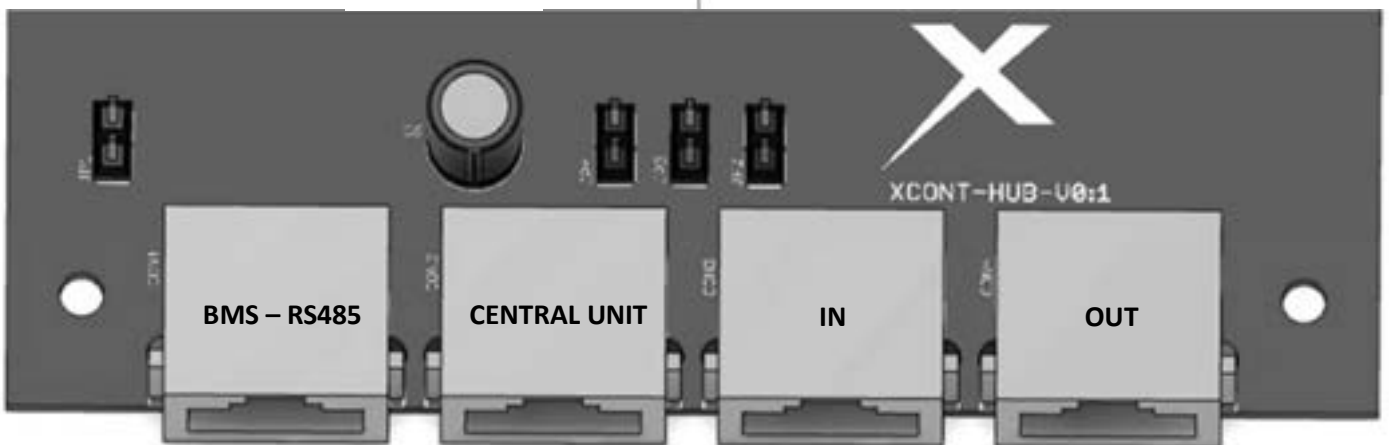
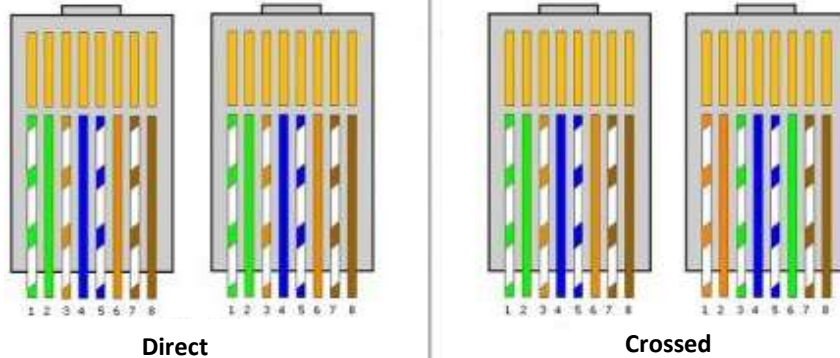

- To connect the unit controller, use the included data cable (except for the XROOM unit, where it is already integrated in the unit body - see the unit manual) with a length of 1 m. The cable is used exclusively to connect the unit driver and the socket for the network connector marked BMS-RS485.



- The BMS-RS485 socket must not be used for equipment other than the one specified, there is a risk of damage.

Modbus box connection - Xcont-Hub (CENTRAL UNIT, IN and OUT sockets) - chaining, to the central unit

- sockets marked CENTRAL UNIT, IN, OUT are mutually compatible and it is possible to use them all for the purpose of connecting other XCONT-HUB (chaining) or for connecting other RS485 devices with modbus protocol (central units, other devices...)

CENTRAL UNIT, IN and OUT socket pins

- To connect other devices (apart from the controllers of the heat recovery units and other XCONT-HUBs) it is necessary to observe the meaning of the individual wires within the RJ45 connector. The connector connected to the Central unit, IN or OUT jacks must be connected as shown in the following figure.



Pins 1,2,7,8 has stay unconnected
Pins 3,4 – data wire A hub RS485
Pins 5,6 – data wire B hub RS485

Connection possibilities of Xcont-HUB

- Connection of one unit

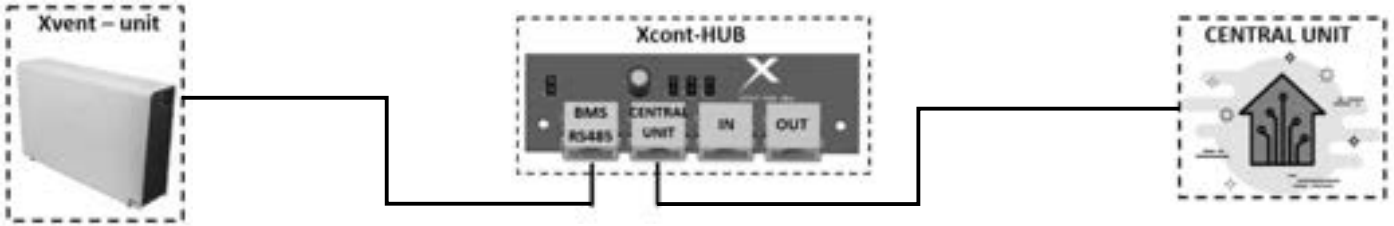

- An example of chaining of the units nr.1

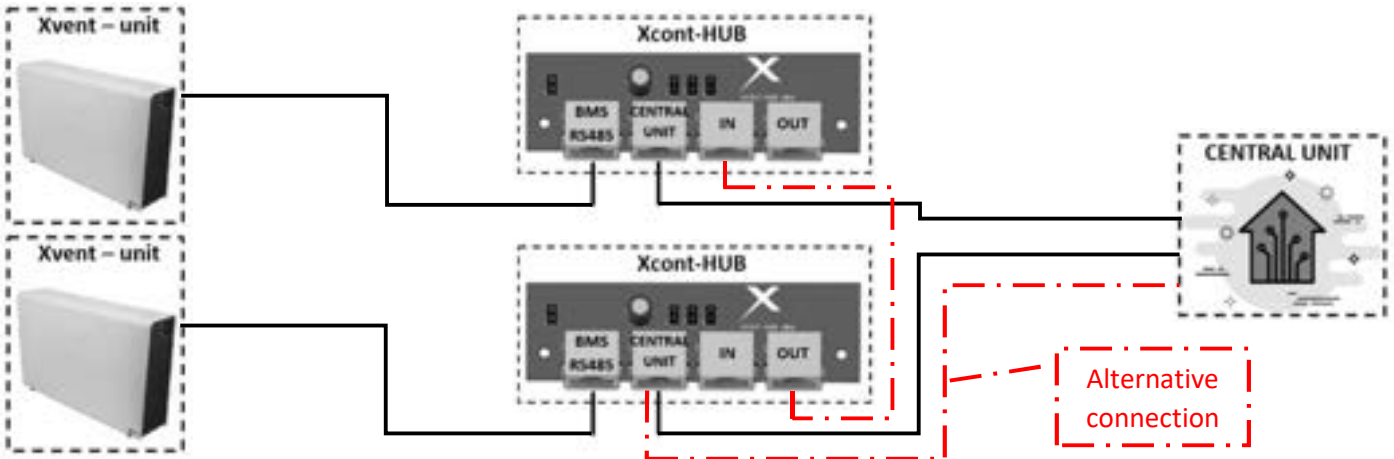

- An example of chaining of the units nr.2

