



## OPERATION AND INSTALLATION INSTRUCTIONS

** ELEMENTAIR**  
E-MARK II

## CONTENS

1.	General information .....	3
1.1.	Introduction .....	3
1.2.	Control of delivery and storage .....	3
1.3.	Contents of the package .....	3
1.4.	Before start of installation .....	3
2.	Dimensions of the regulator .....	3
3.	Regulator installation .....	4
3.1.	Regulator location .....	4
3.2.	Installation .....	4
3.3.	Installation in the working position .....	5
3.4.	Electrical installation and electrical connection .....	5
4.	Technical parameters .....	6
5.	Description of regulator .....	6
5.1.	Description of connecting terminals .....	6
6.	Description of the regulator's functionality – modes: .....	8
6.1.	Heating mode – funkctionality: .....	8
6.1.1.	Winter mode – required temperature control (space heating) at the required flow rate at the choice of the user. ....	8
6.1.2.	Summer mode – space thermostat is OFF – off position .....	8
6.1.3.	The speed regulator is set to OFF - off position , the fan control voltage is switched off. ....	8
6.2.	Screening mode – functionality .....	8
6.2.1.	Winter mode – temperature control required (space heating). ....	8
6.2.2.	Summer mode – the room thermostat is in the OFF position .....	8
6.3.	OFF position .....	8
7.	Recommended electrical wiring .....	9
8.	Regulator maintenance .....	9
9.	Service .....	9
10.	Decommissioning and recycling .....	9
11.	Warranty .....	9
12.	Conclusion .....	10

## 1. General information

### 1.1. Introduction

- This document "Installation and Operating Manual" is intended for the Elementair-E-M2 regulator (hereinafter referred to as "the regulator") to continuously control the speed of the EC-motors for the fans. Detailed familiarisation with this document is important for the correct and safe installation and operation of the regulator.
- Failure to comply with the conditions specified in this document may result in the regulator not working.
- The regulator may only be mounted and connected by a trained person with the appropriate authorization to connect electrical equipment with suitable tools and means. During the assembly, it is necessary to observe all the instructions and recommendations in this manual.
- For the correct operation and long-term service life of the regulator, it is necessary to prevent access of unauthorized persons and to train the regulator operators according to this document and applicable legislative regulations.
- Documentation must always be available at the location of the controller installation. It is forbidden to intervene in any way in the controller's internal wiring, which does not correspond to the instructions given in this manual.
- Due to the continuous development of our products, we reserve the right to change this manual without prior notice.

### 1.2. Control of delivery and storage

- Before starting the installation and before unpacking the regulator from the box, it is necessary to check for any traces of damage on the packaging. In case of damage to the packaging, please contact your carrier.
- Check if the product ordered by you is in agreement. After unpacking, check that the regulator and other components are in order.
- Please report any non-conformity with the order to the supplier immediately. If an order complaint is not made immediately after delivery, it will not be taken into account later.
- If the regulator is not installed immediately after purchase, it must be stored in an internal, non-condensing environment at temperatures in the range 0 to 40°C.
- If the product has been transported at temperatures lower than 0°C, it must be stored after unpacking for at least 2 hours in the working environment where it will be installed.

### 1.3. Contents of the package

- |                                    |    |
|------------------------------------|----|
| - Regulator Elementair-E-M2        | 1x |
| - Quick manual + Safety Data Sheet | 1x |
| - Name plate                       | 1x |

### 1.4. Before start of installation

- Before commencing the installation, we recommend to stick the serial plate (normally delivered in the package) to the operating documentation (Quick manual, operating book of the equipment, etc.), which is subsequently stored for possible later servicing.
- Before starting all installation or maintenance work, it is necessary to switch off the power supply and secure the switch against switching it on again.

## 2. Dimensions of the regulator

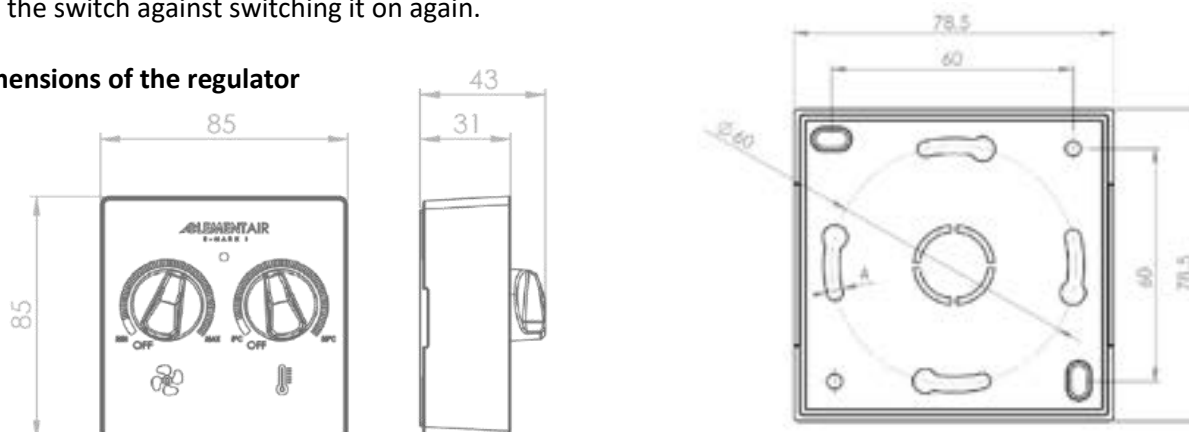

### 3. Regulator installation

#### 3.1. Regulator location

- The regulator is designed for wall installation in the interior environment of buildings. For proper functioning, the regulator must be located at the reference point – in the residence zone about 1.5 m above the floor; it must not be close to the door or window openings in the area where is a natural air movement (draft), direct sun light or any sources radiant heat.
- The maximum recommended distance of the regulator from the regulated EC-motor is 100 m at the conductor cross-section of 1 mm<sup>2</sup>.
- Ambient working temperature 0 to 40°C, humidity 0-90% non-condensing.

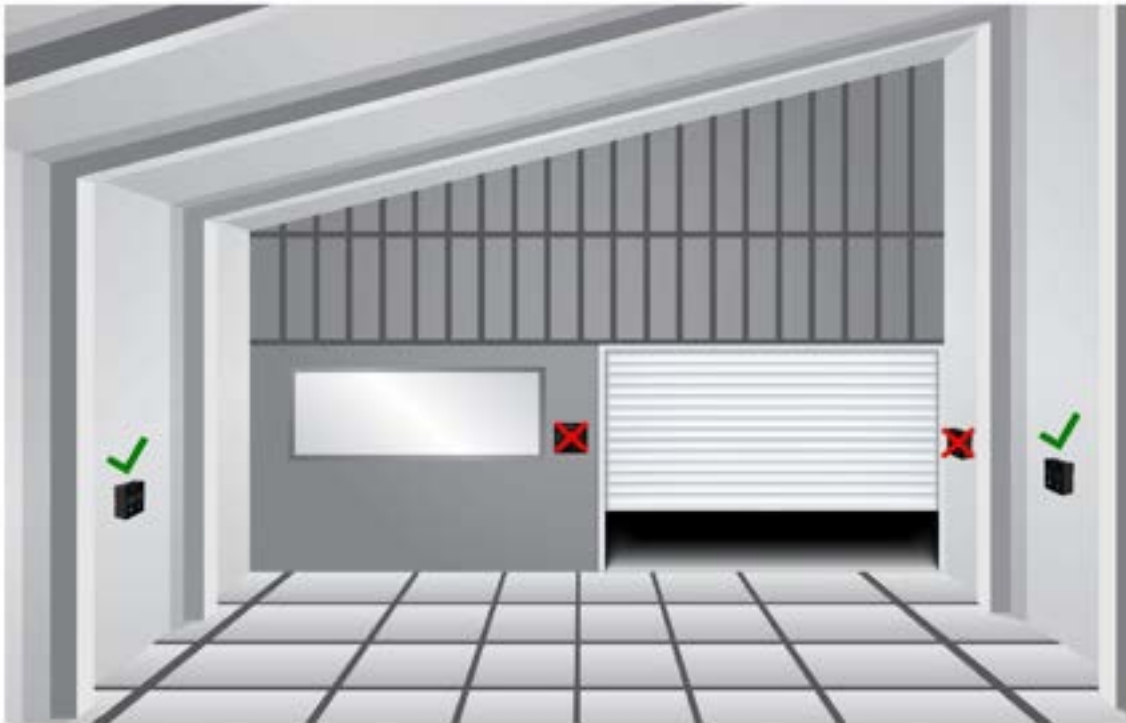

#### 3.2. Installation

- The regulator can be mounted on a wall:
  - o In an under-plaster electrical junction box (hereinafter referred to as the boxes) with the central opening for the supply cable. The supply cable must be prepared in the wall. Connect the cable according to the relevant wiring diagram. Complete the assembly with mounting the front cover - by snapping in.
  - o In an under-plaster electrical junction box (hereinafter referred to as the boxes) with the central opening for the supply cable. The supply cable must be prepared in the wall. Connect the cable according to the relevant wiring diagram. Complete the assembly with mounting the front cover - by snapping in.



INSTALLATION ON UNDER-PLASTER OR SURFACE-MOUNTED ELECTRICAL JUNCTION BOX

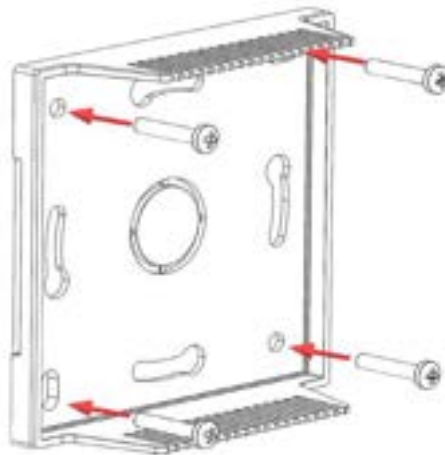

CONNECTING POWER SUPPLY AND CONTROL CABLES

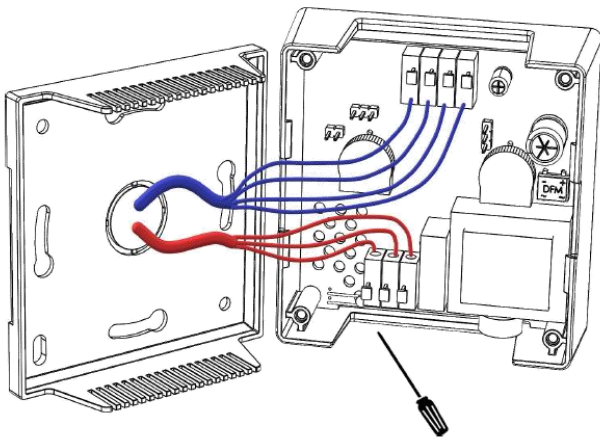

COMPLETING THE CONTROL PANEL AFTER CONNECTING  
(ALIGN THE CABLES TO AVOID DAMAGE)

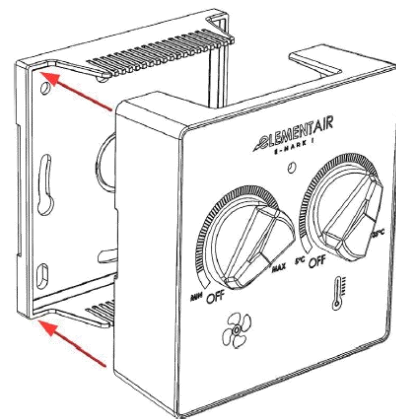

**3.3. Installation in the working position**

- The regulator is mounted on the wall in the vertical position – the side vents are facing down and up.
- The regulator shall be installed in such a way that air can flow around and the overheating is avoided.
- The regulator installation must be carried out in a place where sufficient and safe access will be provided in the event of control, maintenance, servicing.
- The regulator must be mounted in such a way that the minimum spacing distances of 100 mm from all constructional structures and flammable substances or the distances based on local regulations are respected.

**3.4. Electrical installation and electrical connection**



**The regulator must always be disconnected from the main power supply before any intervention.**

**The regulator connection shall be in accordance with the relevant standards.**

- **The work may only be performed by a worker with professional qualifications. The regulator must be connected to the mains by means of an insulated cable in accordance with the diameter and the corresponding regulations.**
- **The power supply phase to the regulator shall be connected via a protection power circuit breaker of the corresponding current rating and type.**
- **The maximum recommended distance of the regulator from the regulated EC-motor is 100 m, and the conductor cross-section 1 mm<sup>2</sup>. It is possible to increase or reduce the distance according to the selected conductor cross section and the calculation of real voltage loss.**
- **In the event of fire, the regulator must be extinguished with CO<sub>2</sub> or a powder-type fire extinguisher.**
- **The supply voltage of the regulator shall be connected so that it can be disconnected from the source by one element**

#### 4. Technical parameters

- Input voltage 1~230VAC 50/60Hz
- Current 5A
- Temperature control range 5-35°C
- Protection IP20
- Weight 0,16Kg

#### 5. Description of regulator

- The regulator is used to continuously control the speed of EC fan.
- The fan speed may also be controlled by an integrated space thermostat, depending on the temperature of the space.
- The fan speed control and thermostat control are with continuous regulation on the front panel of the regulator.
- For information on the operation of the connected equipment, a signal diode is located between the control elements (buttons).
- Furthermore, the regulator is equipped with a phase contact 1~230VAC and a low-potential contact 12 VDC.
- The regulator is designed for wall installation.



**Signalling diode** – signals the operation of the entire regulator. If the diode is lit, the regulator is active. If the regulator is not on, it is switched off.

**Spatial thermostat** – allows the setting of the required temperature in the range of 5 to 35°C. Based on the difference between the ambient temperature and the required temperature, the connected equipment is switched off or switched on.

**Continuous fan speed regulator** – allows smooth fan speed setting in any position from minimum to maximum fan speed as required by the user. The "OFF" position allows the entire regulator to be switched off. The "OFF" position does not provide disconnection of the controlled equipment from the supply voltage – it must be performed separately on the supply

#### 5.1. Description of connecting terminals

- Spring terminals with manual locking are used to connect the wires. A strand-type conductor (cable) and a solid conductor (wire) in the cross-section range from 0.5 to 1.5 mm<sup>2</sup> can be installed in the terminals. Before inserting the wire into the terminals, first press the locking orange button. Then slip in the wire, release the lock and slightly pull it out of the terminal to verify that the wire is properly secured. If the wire needs to be removed from the terminal, the procedure is the same. The optimum cross-section of the conductor must be selected according to the actual length of the conductor route; however, the cross-section of the conductor may be 1.5 mm<sup>2</sup>.
- All wires shall be connected to terminals with adequate force to prevent damage to them or damage to the electrical board. Stripping of cables to individual conductors should be 10mm. In the case of strand-type conductors, an end piece must be pressed on (tube).

**EC fan connection terminals**

**Description:** terminals for connecting the control voltage from the EC fan PWM/0-10VDC (+); GND (-) with resistance 10kΩ. Regulator control range 2-10VDC. The minimum control voltage under 2V does not guarantee the correct functionality of the EC fan.

**Contact load:** max 2mA

**Recommended cross-section of conductors:** from 0.5 mm<sup>2</sup> to 1.5 mm<sup>2</sup>

**Low-voltage contact – Door Switch**

**Description:** contact is intended for the control of the regulator by means of magnetic contact. The logic of the NC contact switching (break contact). By default, the contact is tripped (door contact functionality is switched off).

**Contact load:** 12VDC / 10 mA

**Recommended cross-section of conductors:** from 0.5 mm<sup>2</sup> to 1.5 mm<sup>2</sup>.

**Jumper**

**Desc.:** switching the modes of fan control

- heating mode – jumper is plug in. (Factory setting)



- Screening mode – jumper is removed

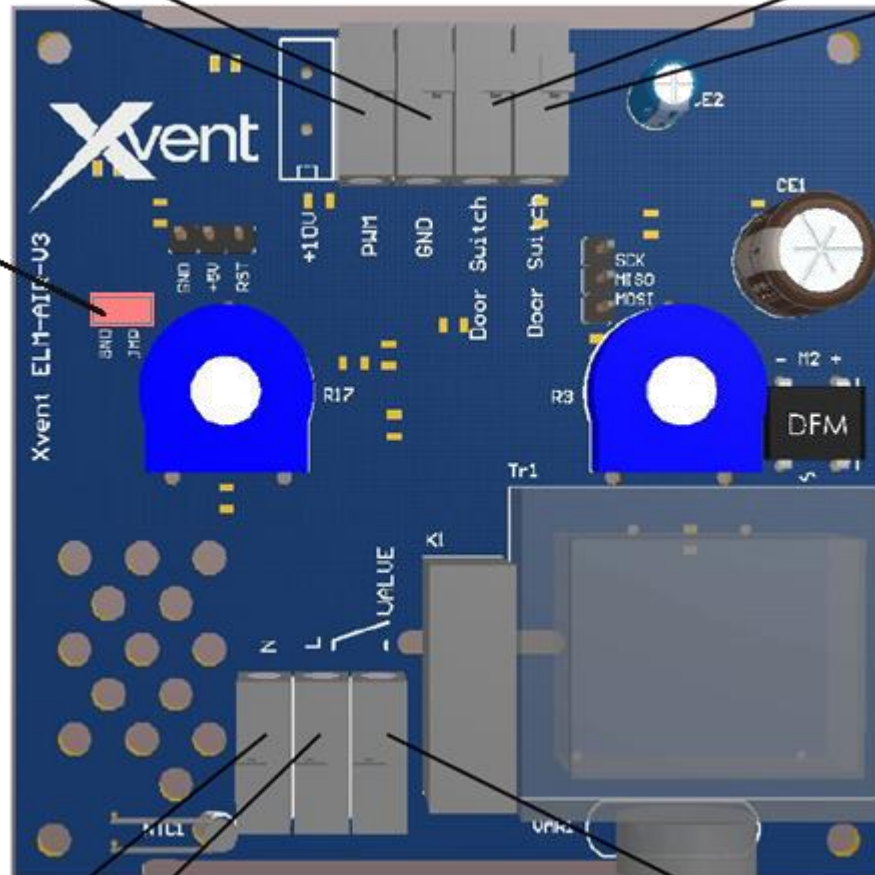

**Regulator power supply**

**Description:** terminals designed for power supply of regulator 1~230VAC 50/60Hz

**Max regulator current capacity:** 230 VAC/5A

**Recommended cross-section of conductors:** 1.5mm<sup>2</sup>

**Phase contact – valve control**

**Description:** Contact intended for control of actuated valve for the exchanger. The contact interrupts/controls only the phase conductor, which is connected to the supply phase in the regulator. The zero/neutral conductor is connected directly from the power supply.

**Max. current capacity:** 230 VAC / 5A - resistive load

**Recommended conductor cross-section:** 1.5mm<sup>2</sup>

## 6. Description of the regulator's functionality – modes:

### 6.1. Heating mode – functionality:

- jumper is plug in
  - 6.1.1. Winter mode** – required temperature control (space heating) at the required flow rate at the choice of the user.
  - The equipment is running at the speed pre-set by the user. When the required temperature is reached, the device is switched off.
  - The actuated valve is open – the equipment is heating. The valve control is by the switching logic, together with the fan. The equipment is switched off, the valve is closed.
  - Low-voltage contact – door switch (sensing the opening of door, gate, windows, etc.) is:
    - o Opened (e.g. door open) – the equipment starts at max. speed; it ignores the spatial thermostat setting. Heating is always at full output – the valve is open.
    - o Closed (e.g. doors closed) – the equipment returns to thermostat control mode, i.e. the equipment is returned to the speed set by the user and is controlled by the spatial thermostat according to the ambient temperature and the required temperature.

### 6.1.2. Summer mode – space thermostat is OFF – off position

- The equipment is running according to the set speed by the user – it is not switching off.
- The valve is closed.
- Low-voltage contact – door switch (sensing the opening of door, gate, windows, etc.) is:
  - o Open (e.g. door open) – the device is driven to max. speed, the valve is closed
  - o Closed (e.g. door closed) - the screen is driven back to the speed selected by the user; the valve is closed.

### 6.1.3. The speed regulator is set to OFF - off position , the fan control voltage is switched off.

### 6.2. Screening mode – functionality

- jumper is not fitted
  - 6.2.1. Winter mode** – temperature control required (space heating).
  - The device runs at minimum speed. When the required temperature is reached, the device switches off.
  - The valve with the actuator is open - the device is heating. The valve control is in the fan switching logic. the device is switched off, the valve is closed.
  - Low voltage contact - door switch (sensing the opening of doors, gates, windows, etc.) is:
    - o Open (eg door open) - the device starts at any speed set by the user, ignores the room thermostat setting. The heating is always full - the valve is open.
    - o Closed (eg door closed) - the device returns to thermostat control mode. ie. the device is operated according to the required temperature:
      - The required temperature is not reached - the device is operated at minimum speed, the valve is open - it heats up.
      - The required temperature has been reached - the device is standing and waiting to start from the thermostat or door switch

### 6.2.2. Summer mode – the room thermostat is in the OFF position

- The valve is closed.
- Low voltage contact - door switch (sensing the opening of doors, gates, windows, etc.) is:
  - o Open (eg door open) - the device starts at any speed set by the user, the heating is switched off - does not heat
  - o Closed (eg door closed) - the device is standing and waiting to start from the door switch

### 6.3. OFF position

- The speed controller is set to the OFF position´
- the fan control voltage is switched off



## 7. Recommended electrical wiring

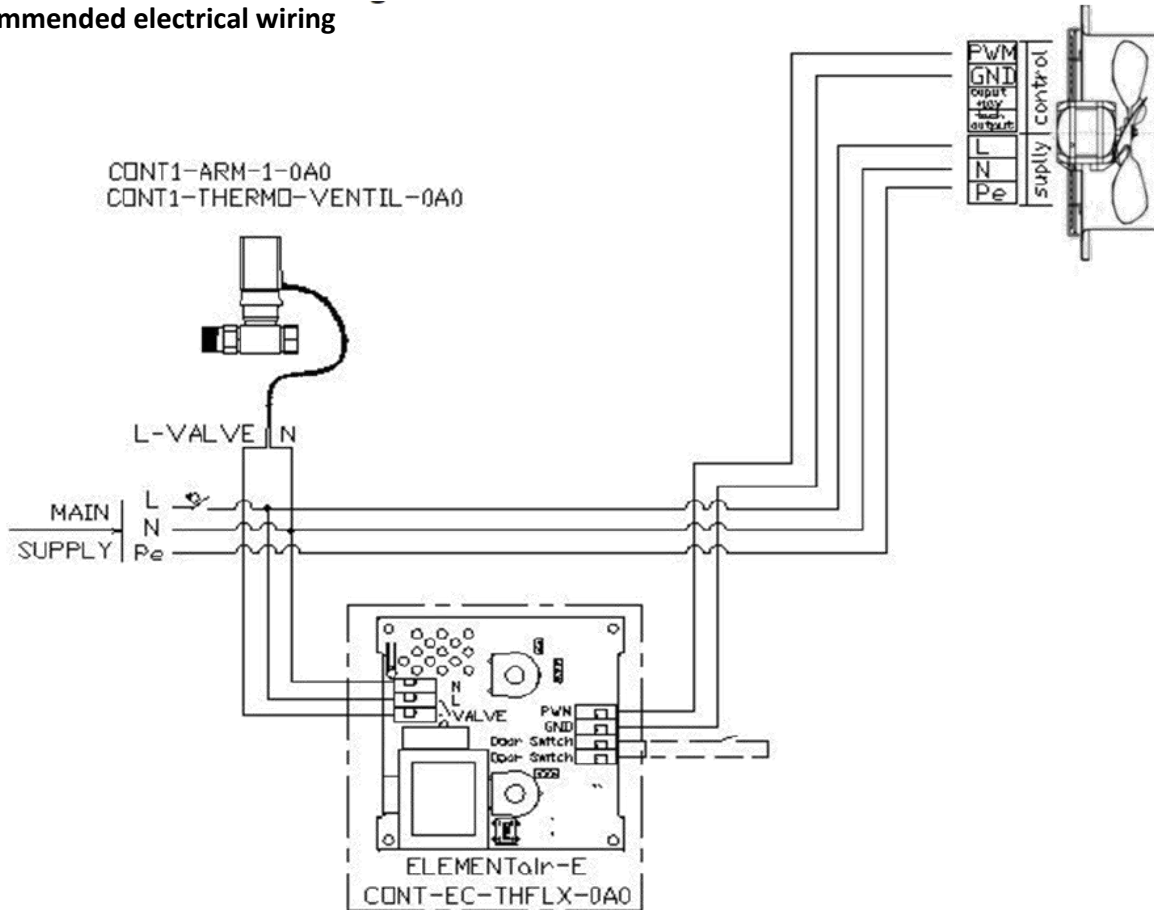

## 8. Regulator maintenance

- The regulator's maintenance consists in cleaning as needed, but at least once a year. Clean the regulator with a vacuum cleaner or fine dry cloth.

## 9. Service

- Observe the generally applicable country-specific provisions. In case of any service activity, the regulator must be disconnected from the mains. Any electrical service work must be carried out by a person with professional qualifications.
- Complete the electrical connection precisely according to the supplied electrical documentation. Always assess the suitability of the use of recommended cable connections with respect to the fire zones of the construction, protective distances, protection and condition of the electrical installation of the construction.
- Connect the prepared cables to the terminals according to the attached electrical documentation, then check the connection before switching on the power supply.

## 10. Decommissioning and recycling



All unused or not operable products and packaging should be returned to the appropriate recycling locations where they will dispose of them in a professional manner. Please dispose the unusable parts of the product in a controlled landfill. Only like this the recycled product can be reused and bring a new benefit.



## 11. Warranty

- We do not guarantee the suitability of using the regulator for special purposes, determination of suitability is fully within the competence of the customer and the designer.
- The regulator warranty is valid according to legal regulations.

- The warranty only applies if all installation and maintenance instructions are followed.
- The warranty covers manufacturing defects, defects in material or defects in the operation of the instrument.
- The warranty does not apply to defects caused by:
  - improper use or project
  - incorrect handling
  - during transport (damage caused by transport and its financial compensation must be resolved with the carrier)
  - incorrect assembly
  - incorrect electrical connection or protection
  - incorrect operation
  - by unprofessional intervention in the regulator
  - wear and tear in a normal manner
  - as a result of a natural disaster
- When applying the warranty, it is necessary to submit a report (part of this document) containing:
  - details of the complaining person/company
  - date and number of the sales document
  - detail defect description
  - wiring diagram and protection data
  - photo of the product's manufacturing label and, where appropriate, serial number
  - photo from the place of product installation
  - product measured values: air temperature, voltage, current
- The method of handling warranty repairs is carried out at the company service centre or at the place of installation. The method of resolving warranty repairs is exclusively at the discretion of the company's service centre. The complaining party shall receive a written statement on the result of the complaint – warranty repairs. In the event of an unjustified complaint, all costs associated with this shall be borne by the complaining Party.

## 12. Conclusion

- If you have any doubts about this product, please do not hesitate to contact us.

### Contact address:

SMART-FLEX Sp. z o.o.  
Mielczarskiego 21/23  
42-202 Częstochowa

