



Xvent
ND



ERP 2020

EC

SCREEN + HEATING

Industrial and commercial air screen

www.xvent.com.pl



Clean design with length of 150cm to 250cm, high heat and air output, intuitive ECmotor control

Thanks to its performance and design , it is suitable for the gates, both in large logistics and production halls, and in smaller shops and warehouses.

Possibility of vertical and horizontal installation.

Silent operation and high barrier effect thanks to thought-out design.

When using a filter (accessory), the heat exchanger is protected against clogging.

Thanks to the speed regulation, the optimum screening and heating power can be selected.

The use of high-quality components makes it possible to provide a warranty for 5 years.

Applicable to gates with height up to 6,5 m and the width up to 14 m.

Nut M6 for hanging on the ceiling, using threaded rods

Pre-blow setting up to 20° thanks to the mounting base included in the package.



The exhaust aluminium lamellas designed by a computer simulation will provide a stable air stream with a high barrier effect.

Quality water exchanger
Connection with mail thread G 1" (max. working conditions 120 °C, 1.6 MPa). Integrated venting valves on the water inlet and outlet

Simple electrical connection thanks to the integrated installation box on the screen body

EC fan
Higher performance and low operating costs Low noise level even at higher power output of the unit, fan speed continuously adjustable 2-10 VDC



Why is the shape of WIND screen optimal

Using CFD simulations (Computational Fluid Dynamics – mathematical-physical numerical gas flow solutions) in **typified spaces**, based on **real installations**, we have reached the optimal screen geometry.

Air throughput
Up to 15 000 m³/h

Horizontal blowing range
Up to 8 m

Heating capacity
6-117 kW

Vertical blowing range
Up to 7 m

Side view

20m

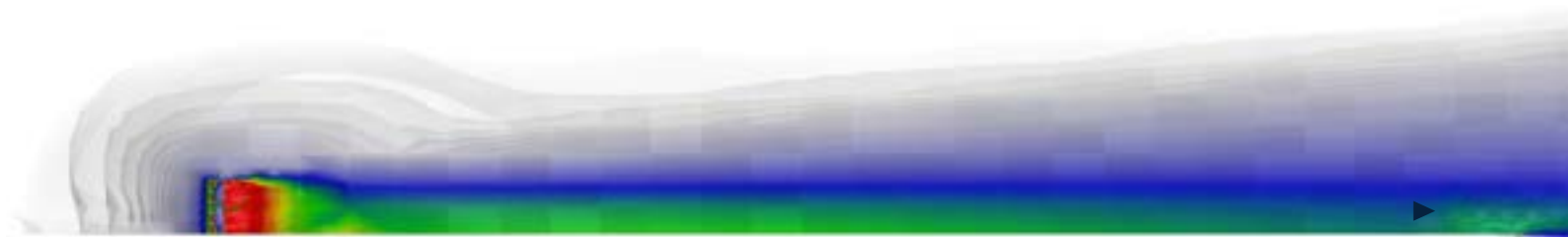

Top view

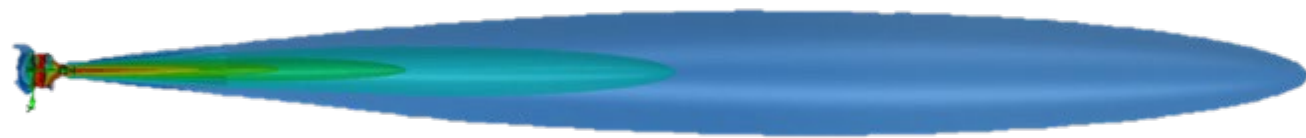

Compact air speed profile

at 3m
(Height of screens 2.5m – WIN1-25)

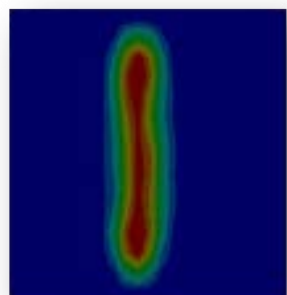

at 6m
(Height of screens 2.5m – WIN1-25)

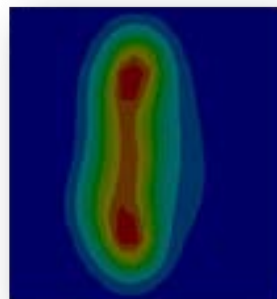

at 7.5m
(Height of screens 2.5m – WIN1-25)

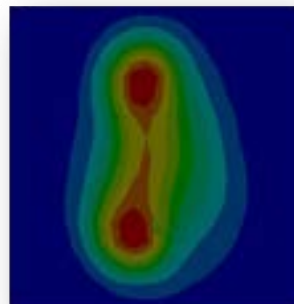

Frequently Asked Questions & Answers

Is the air curtain able to completely prevent cold air from entering the interior areas?

No. But the correctly designed quality screen is capable of dramatically reducing the penetration of cold air. This will make it very comfortable to stay in the area and will significantly reduce energy consumption. However, there are cases where installation of the screen cannot solve the draft problems.

How is the appropriate air screen selected?

The selection depends on the size of the door/gate opening. The greater the opening, the bigger (more powerful) the air screen has to be.

If the air velocity exceeds 7 m/s or 25 km/h in the door/gate opening, the use of the air screen will be ineffective and the door opening must be protected by other means (e.g. by a door or a change of position).

How does the air barrier function as a heating unit?

The air screen belongs to the category of hot-air heating units with strictly specified rules for its selection, location and installation. It is generally assumed that 85% (!) of the heat supplied by the screen remains in the protected area. According to our experience, in a large number of cases the screen itself is capable of heating the space where it is installed. Many heating technicians do not know this, so they ignore this fact and suggest heating without respecting this source.

What is the purpose of the air screen?

The air screen is a heating device designed to protect the door openings against entrance of cold air in the interior of building.

How does the air screen work?

The air screen creates a strong compact air stream; it is possible to imagine it as a heavy curtain located in the door or gate opening when the door/gate is open, and it prevents the cold outside air from penetrating into the building and thus cooling it down.

How will a quality screen become known?

A high-quality air barrier shall be capable of generating a strong, compact air flow, the speed of which decreases as slowly as possible with the distance from the exhaust point. This property is called blowing range. A good-quality air screen should be as quiet as possible so that it does not disturb people in its vicinity with excessive noise.

How to install the air screen?

The air screen is installed either next to or above the door opening. The screen exhaust must always be directed out of the door/gate. The angle between the flow axis and the door plane is called the pre-blow. It is ideal if the air screen allows adjustment even after assembly depending on the actual conditions at the place of installation and the request of the users after the first experience.

How to install the screen WIND?

Door screens can be installed vertically on the floor and horizontally suspended on the ceiling or a wall.

Vertical installations

For the most effective operation of the screen, it is necessary to extend the screen above the door opening

Horizontal installation

For the most effective operation of the screen, it is necessary to make an overlap on both sides of the door; suspension either on threaded bars or on supporting structure anchored to the wall (not supplied by Xvent).

Use anchors with sufficient strength to attach the console to the floor - oval openings max. with M10

For correct operation of the WIND screen, the minimum distance of 0.4 m between the outer shell of the unit and the wall or ceiling must be observed. Failure to observe these distances may result in incorrect function of the unit, damage to the fan or excessive noise of the unit. For horizontal installations on the ceiling, the minimum distance of 0.21 m between the unit fan and the ceiling (suction space) shall be respected.

Tip for the ceiling installations

Create the door opening connecting lines, and turn the screen accordingly. This applies both to the vertical and horizontal execution.

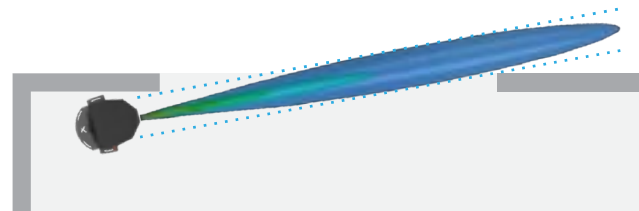

Chained screen mounting

The mounting stand (console) is included in the packaging. The connecting part for chaining must be purchased separately as accessory.

Using the M6 screws, fasten the console to the screens and then chain the screens together using the M8-M10 nuts/screws.



Screen pre-blow setting for the most efficient operation of the screen WIND

The pre-blow of the screen is important for the correct operation of the screen – weather conditions that influence the door opening could disrupt the air stream blowing from the screen and can then "push it towards the building".

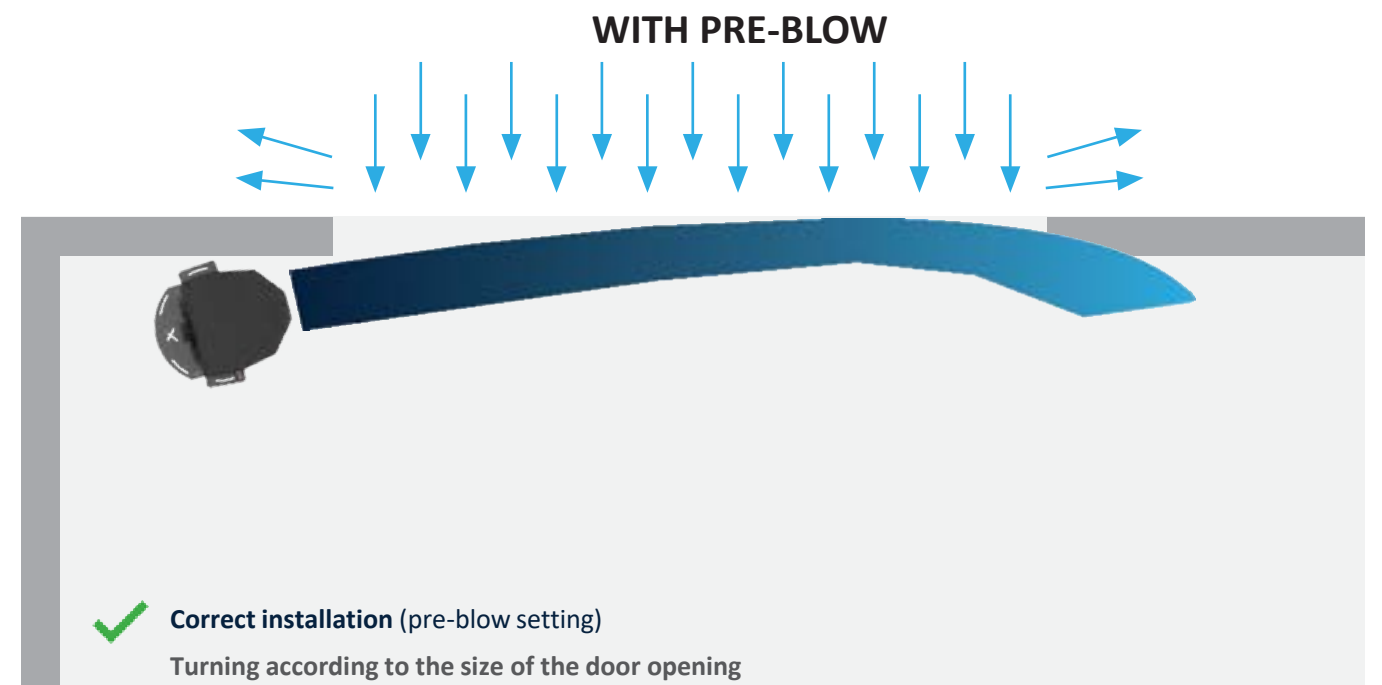
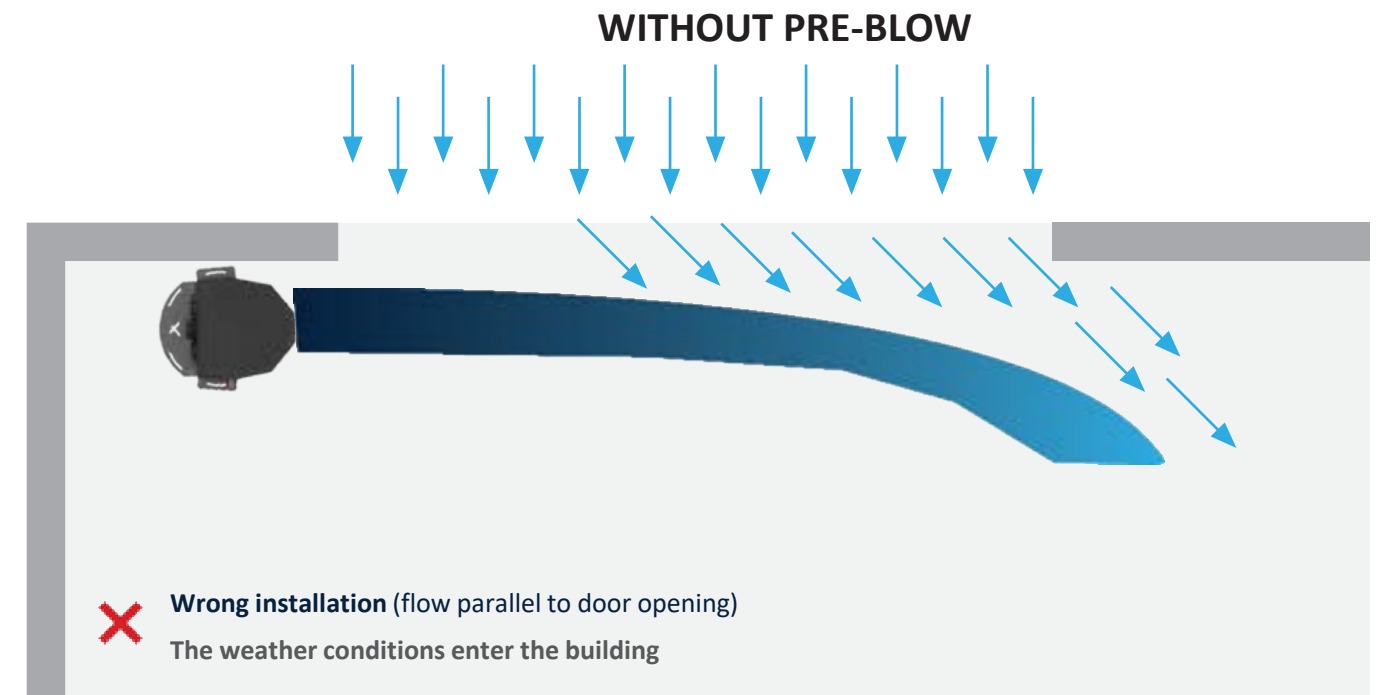

Horizontal industrial installation



Vertical industrial installation



Commercial areas

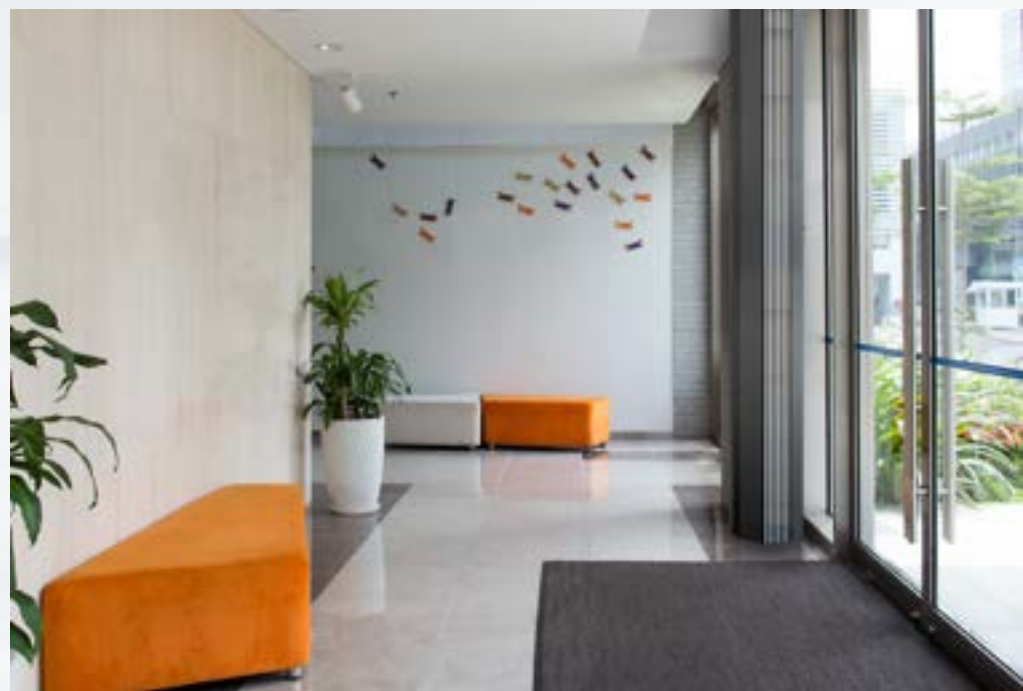

Accessories for the WIND unit



Controls for the EC fans

- Continuous adjustment of fan speed with a 0–10V DC signal
- Integrated room thermostat
- Option to connect a control valve with on/off drive
- Independent on/off heating control
- Fan deactivation upon reaching the required temperature at the thermostat

All tested and integrated into a single controller.

Motor type in the unit	EC
Input voltage	1 ~ 230/50-60
Output signal	0–10V
Permissible load	0.02 A
Temperature adj. range	5–35 °C
Temperature sensor	integrated
Cover	IP20
Package dimensions (height x width x depth)	85x85x30mm
Gross weight	0.25 kg
Net weight	0.2 kg
Sales Code	ELEMENTAIR-E-M1

Power supply	230/50-60 V/Hz
Power consumption	2 W
Connection dimension	3/4 "
Maximum medium temperature	120 °C
Max Ambient Temperature	50 °C
Cover - in any position	IP 44
Gross weight	0.3 kg
Net weight	0.3 kg
Package dimensions (height x width x depth)	120 x 120 x 120
Sales Code	'MTA-230-NC V2050DH025'

Name	Filter
Screen size	WIND-15,20,25
Filtration class	G2 (ISO Coarse)
Gross weight	0.1
Net weight	0.1
Package dimensions (height x width x depth)	300 x 220 x 50
Sales Code	FILTER-350

Servo-driven valve

Allows to switch water on/off, based on the temperature measured by the room thermostat.



Fan intake filter ATA1-FILTER

Filters on fan intake ATA1-2-FILTER-G2, ATA1-4-FILTER-G2 are used to collect rougher dust particles, making the room environment cleaner for persons at the place of installation.



Magnetic contact B-3

Maximum switching voltage	100 V
Maximum switching current	0.4 A
"Contact closing distance - mounting distance"	38 mm
Contact disconnection distance	42 mm
Contact type	NC (break contact)
Operating temperature range	-10 to +55 °C
Maximum relative humidity	90 %
Dimensions of the magnet cover	50x17x9.8 mm
cable length/wire cross-section	680/ 0.5 mm/mm ²
Package dimensions (height x width x depth)	„100 x 70 x 10 mm
Gross weight	0.07 kg
Net weight	0.056 kg
Sales Code	B3

Pedestal/Hinge

Screen size	WIND15,20,25
Gross weight	3.5 kg
Net weight	2.8 kg
Dimensions (height x width x depth)	60X610x400 mm
Sales Code	WIND-HOLDER



Connecting part

Unit size	WIND15,20,25
Gross weight	2.2 kg
Net weight	1.8 kg
Dimensions (height x width x depth)	120x540x140 mm
Sales Code	WIND-CONNECT



EC regulation description for WIND screen

Dial for continuous adjustment of fan speed
To set the required fan speed and switch off the fan -OFF



Indicator diode – indicates the operation of the regulator

Room thermostat for setting the required temperature in the range of 5 to 35°C with thermostat off-option -OFF

The regulator allows smooth speed control of the EC fan for air screens, depending on the heated space temperature. With the possibility of control functionality using a door sensor (door closed / open).

The regulator must be connected as per the recommended electrical diagram and the selected product variant. Electrical wiring may only be carried out only by persons with the appropriate authorisation and in accordance with the applicable local regulations.

Description of control elements of the controller – ELEMENTAIR-E-M1

It enables smooth adjustment of the fan speed in any position from the minimum to the maximum fan speed, as required by the user. It also has the option to use the "OFF" end position to disable the room thermostat. The "OFF" position does not provide disconnection of the air screens from the supply voltage – it must be performed separately on the supply line.

Room thermostat – allows setting of the required temperature from 5 to 35°C. Based on the difference between the ambient temperature and the required temperature, the fan is switched off or on. It also makes it possible to switch off the function of the spatial thermostat by selecting "OFF" position.

It is signalling the operation of the entire regulator. If the diode is lit, the regulator is on. If the regulator is not on, it is switched off.

Description of the logic of the regulation:

- **Winter mode** – space heating to the required temperature.
 - The screen runs at the speed set by the user. When the required temperature is reached, the screen is switched off.
 - The actuated valve is open – the screen is heating. The valve control is in the switching logic relationship with the screen. The screen is switched off, the valve is closed.
 - Doors (the screened opening - door, gate, window, etc.) are:
 - open – the screen travels to the maximum speed, ignores the setting of the spatial thermostat, and the valve is set for heating - it is open
 - Closed – the screen returns to thermostat control mode, i.e. the screen is returned to the speed set by the user and is controlled by the spatial thermostat according to the ambient temperature and the required temperature.
- **Summer mode** – no heating by the screen; it is used to separate indoor air from outdoor hot air
 - the screen is switched off using a thermostat
 - The valve is closed.
 - Doors (the screened opening - door, gate, window, etc.) are:
 - open – the screen is driven to max. speed
 - closed – the screen will return to its original state
- The speed regulator is in the OFF position, the unit is switched off.

Recommended accessories for the WIND screen connected to the regulator– ELEMENTAIR-E-M1

V2050DH025 - (2-way valve, 1" valve)

MTA-230-NC - (thermoelectric drive for the valve)

B3 (door contact) – allows the screen to react to a closed or open door, gate, window, etc.

Allows to close/open the heating water supply.

Possible chaining of WIND air screens

Different combinations of WIND air screen lengths can be connected to one regulator, but with a maximum number of 25 fans. Max. number of connected actuated valves is 8 pcs.

Number of fans in the WIND screen:	Screen type	Number of fans
	WIN1-15X-ECXX	3 pcs
	WIN1-20X-ECXX	4 pcs
	WIN1-25X-ECXX	5 pcs

Recommended electrical wiring

Example diagram of regulator wiring with the WIND air screen.

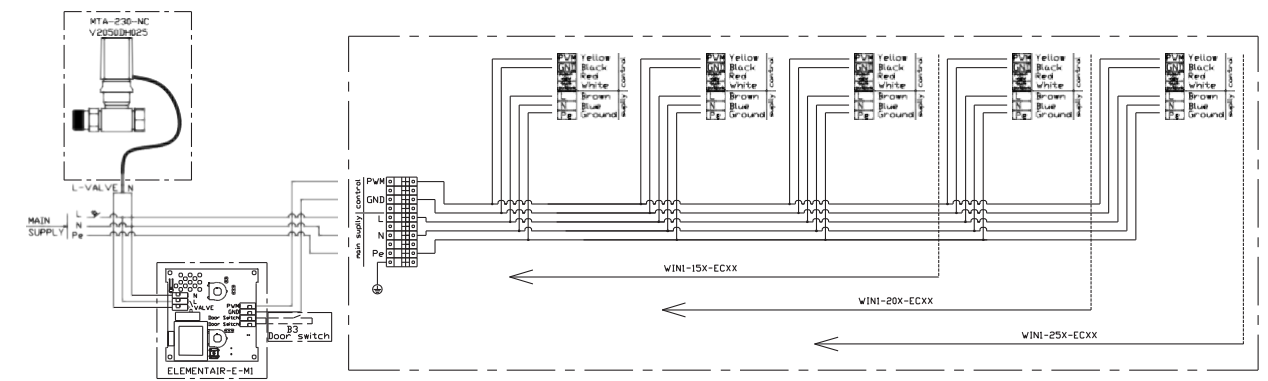

Example diagram of regulator wiring with the WIND air screen chaining.

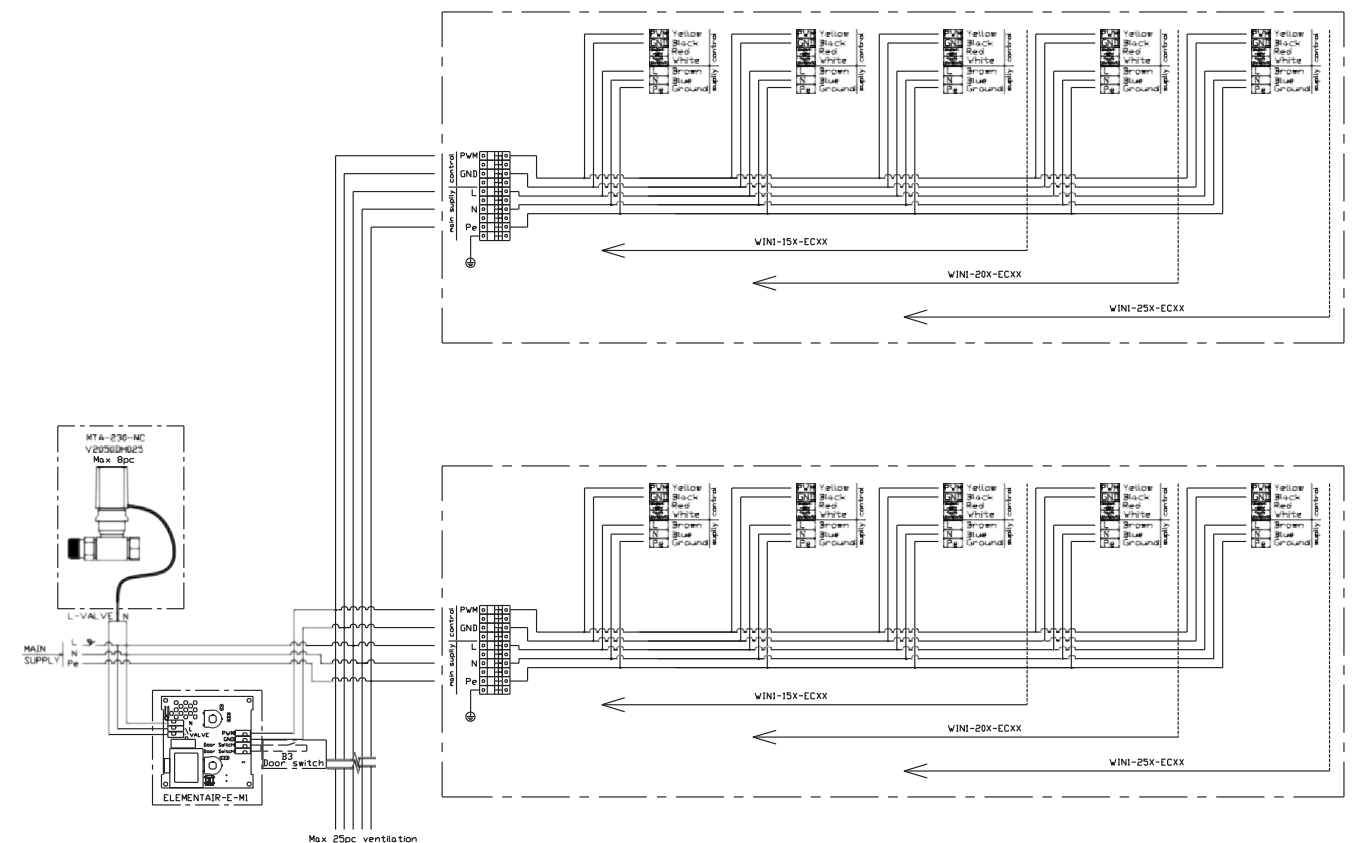

Technical parameters of the model series of WIND screens

Heat exchanger parameters:

Maximum operating water temperature 120 °C

Maximum service pressure 1.6 MPa

Connecting dimensions for all exchangers are with mail thread G 1".

Packaging

Code	Wight		dimensions of packaging	
	Brutto	Netto		
	kg	kg	m	
WIND-15	WIN1-15A-ECS0-0A0	47,8	42,8	0,6x0,8x1,57
	WIN1-15A-ECV1-0A0	55	50	
	WIN1-15A-ECV2-0A0	59	54	
	WIN1-15B-ECS0-0A0	49,4	44,4	
	WIN1-15B-ECV1-0A0	57	52	
WIND-20	WIN1-15B-ECV2-0A0	61	56	0,6x0,8x2,055
	WIN1-20A-ECS0-0A0	52,7	47,7	
	WIN1-20A-ECV1-0A0	58,8	53,8	
	WIN1-20A-ECV2-0A0	62,8	57,8	
	WIN1-20B-ECS0-0A0	58,9	53,9	
WIND-25	WIN1-20B-ECV1-0A0	67	62	0,6x0,8x2,54
	WIN1-20B-ECV2-0A0	69	64	
	WIN1-25A-ECS0-0A0	76,1	71,1	
	WIN1-25A-ECV1-0A0	84,5	79,5	
	WIN1-25A-ECV2-0A0	88,5	83,5	
	WIN1-25B-ECS0-0A0	83,6	78,6	
	WIN1-25B-ECV1-0A0	92	87	
	WIN1-25B-ECV2-0A0	96	91	

Technical data

		WIND-15A		WIND-15B		WIND-20A		WIND-20B		WIND-25A		WIND-25B							
		EC																	
Air flow	m3/h	7750	7000	6750	9000	8300	7800	10350	9300	9000	12000	11000	10400	12900	11900	11250	15000	13500	13000
Heat output range	kW	-	-	6-63	-	-	8-69	-	-	8-86	-	-	11-94	-	10-107	-	-	13-117	-
Number of exchanger rows	-	-	1	2	-	1	2	-	1	2	-	1	2	-	1	2	-	1	2
Working information of exchanger		maximální provozní teplota vody 120°C; maximální provozní tlak 1,6Mpa; přípojovací rozměr potrubí G 1"																	
Maximal horizontal range *	m	7	6,5	6,5	8	7	7	7	6,5	6,5	8	7	7	7	6,5	6,5	8	7	7
Maximal vertical range *	m	6	6	6	7	6	6	6	6	6	7	6	6	6	6	6	7	6	6
Noise level **	dB(A)	49,9	49	49	60,9	58,8	58,8	52	51	51	62,7	60,3	60,6	53,2	52,3	52,3	63,7	61,7	61,7
Unit weight ***	kg	42,8	50	54	44,4	52	56	47,7	53,8	57,8	53,9	62	64	71,1	79,5	83,5	78,6	87	91
Capacity of water in exchange	dm3	-	-	3,4	-	-	3,4	-	-	4,6	-	-	4,6	-	5,7	-	-	-	5,7
Power supply	V/Hz	1 ~ 230/50-60			1 ~ 230/50-60			1 ~ 230/50-60			1 ~ 230/50-60			1 ~ 230/50-60			1 ~ 230/50-60		
Motor output	W	317	337	337	511	517	517	423	450	450	687	708	708	528	562	562	822	853	853
Motor current	A	2,14	2,24	2,24	3,37	3,3	3,3	2,85	2,99	2,99	4,53	4,52	4,52	3,57	3,73	3,73	5,42	5,45	5,45
Speed	ot/min	1370	1360	1360	1750	1650	1650	1370	1360	1360	1750	1670	1670	1370	1360	1360	1750	1610	1610
IP range	IP	54			54			54			54			54			54		
Sales code	-	WIN1-15A-ECS0-0A0	WIN1-15A-ECV1-0A0	WIN1-15A-ECV2-0A0	WIN1-15B-ECS0-0A0	WIN1-15B-ECV1-0A0	WIN1-15B-ECV2-0A0	WIN1-20A-ECS0-0A0	WIN1-20A-ECV1-0A0	WIN1-20A-ECV2-0A0	WIN1-20B-ECS0-0A0	WIN1-20B-ECV1-0A0	WIN1-20B-ECV2-0A0	WIN1-25A-ECS0-0A0	WIN1-25A-ECV1-0A0	WIN1-25A-ECV2-0A0	WIN1-25B-ECS0-0A0	WIN1-25B-ECV1-0A0	WIN1-25B-ECV2-0A0

* Maximum range of air flow at 3m/s air speed

** Sound pressure level in 3m, Q=2

*** unit weight, no water

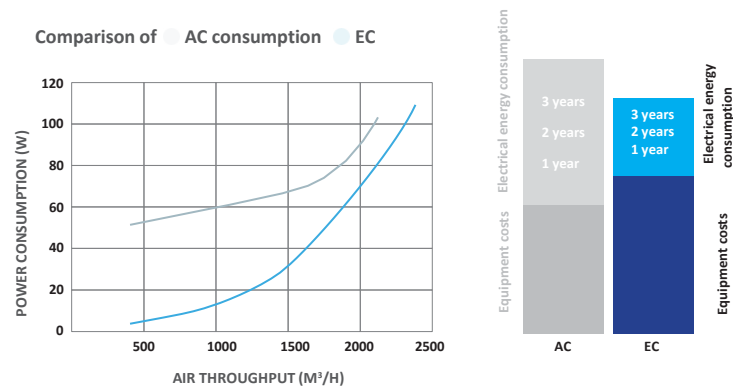
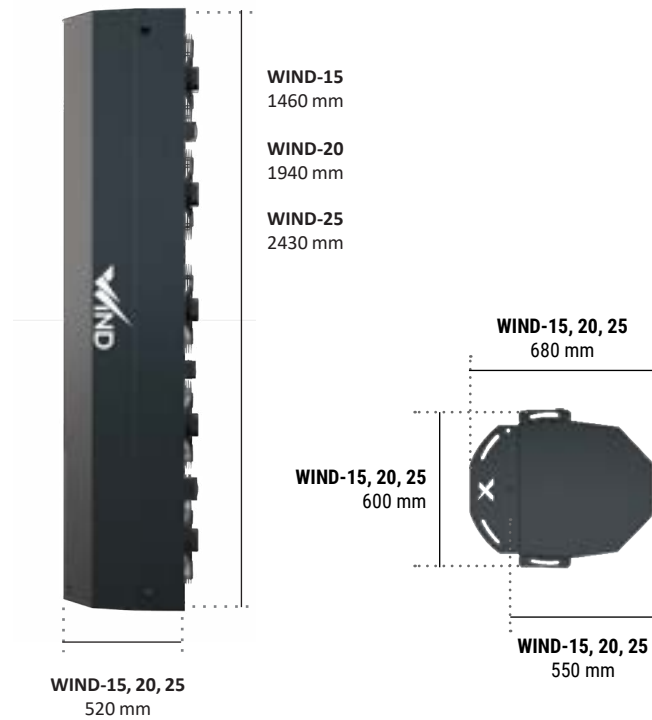

WIN1-15A-ECS0-0A0

WIND 15 – EXECUTION EC

Fan speed *	Air throughput	Unit current	Power consumption of the unit	Acoustic power in frequency bands (dB)								Noise level		
				63 Hz	125 Hz	250 Hz	500 Hz	1 kHz	2 kHz	4 kHz	8 kHz	LwA	LPA*	
	m3/h	A/230V/Hz	W	dB	dB	dB	dB	dB	dB	dB	dB	dB	dB	dB
III	7750	2.14/230/50-60	317	39.9	57.7	63.9	65.4	67.1	63.9	57.4	50.7	71.7	49.9	
II	4700	0.62/230/50-60	77	36.9	47.3	52.7	55.5	54.0	50.6	43.1	34.6	59.9	38.2	
I	2000	0.21/230/50-60	10	34.4	45.1	45.3	49.5	44.3	41.8	32.6	27.5	53.1	31.3	

* The specified air flow rates correspond to the maximum, mean and minimum flow rates

** Sound pressure level in 3m, Q=2

WIN1-15A-ECVx-0A0

WIND 15 – EXECUTION EC

Fan speed *	Air throughput	Unit current	Power consumption of the unit	Acoustic power in frequency bands (dB)								Noise level	
				63 Hz	125 Hz	250 Hz	500 Hz	1 kHz	2 kHz	4 kHz	8 kHz	LwA	LPA*
	m3/h	A/230V/Hz	W	dB	dB	dB	dB	dB	dB	dB	dB	dB	dB
III	6750	2.24/230/50-60	337	37.1	57.3	62.9	64.3	65.8	63.7	57.5	49.8	70.8	49.0
II	3950	0.63/230/50-60	86	35.3	43.5	52.2	53.8	53.7	50.4	42.4	33.0	59.0	37.2
I	1300	0.22/230/50-60	10	22.0	36.8	42.0	45.7	40.5	35.6	26.2	22.3	48.7	26.9

* The specified air flow rates correspond to the maximum, mean and minimum flow rates

** Sound pressure level in 3m, Q=2

WIN1-15B-ECS0-0A0

WIND 15 – EXECUTION EC

Fan speed *	Air throughput	Unit current	Power consumption of the unit	Acoustic power in frequency bands (dB)								Noise level	
				63 Hz	125 Hz	250 Hz	500 Hz	1 kHz	2 kHz	4 kHz	8 kHz	LwA	LPA*
	m3/h	A/230V/Hz	W	dB	dB	dB	dB	dB	dB	dB	dB	dB	dB
III	9000	3.37/230/50-60	511	44.6	65.7	74.9	76.6	78.0	75.4	68.5	59.3	82.7	60.9
II	5500	1.22/230/50-60	178	37.7	57.4	66.6	65.8	67.4	64.5	56.1	45.6	72.5	50.7
I	2350	0.24/230/50-60	18	17.1	35.0	48.8	42.7	40.8	33.5	24.3	19.8	50.5	28.7

* The specified air flow rates correspond to the maximum, mean and minimum flow rates

** Sound pressure level in 3m, Q=2

WIN1-15B-ECVx-0A0

WIND 15 – EXECUTION EC

Fan speed *	Air throughput	Unit current	Power consumption of the unit	Acoustic power in frequency bands (dB)								Noise level	
				63 Hz	125 Hz	250 Hz	500 Hz	1 kHz	2 kHz	4 kHz	8 kHz	LwA	LPA*
	m3/h	A/230V/Hz	W	dB	dB	dB	dB	dB	dB	dB	dB	dB	dB
III	7800	3.30/230/50-60	517	43.2	65.0	74.0	74.3	75.2	72.9	66.3	56.8	80.5	58.8
II	5200	1.31/230/50-60	205	39.7	57.6	65.9	64.9	66.4	63.8	55.4	44.5	71.7	49.9
I	1950	0.24/230/50-60	19	16.5	33.1	55.9	39.7	36.8	30.2	24.5	20.6	56.1	34.3

* The specified air flow rates correspond to the maximum, mean and minimum flow rates

** Sound pressure level in 3m, Q=2

WIN1-20A-ECS0-0A0

WIND 20 – EXECUTION EC

Fan speed *	Air throughput	Unit current	Power consumption of the unit	Acoustic power in frequency bands (dB)								Noise level	
				63 Hz	125 Hz	250 Hz	500 Hz	1 kHz	2 kHz	4 kHz	8 kHz	LwA	LPA*
				dB	dB	dB	dB	dB	dB	dB	dB	dB	dB
	m3/h	A/230V/Hz	W										
III	10350	2.85/230/50-60	423	42.5	60.0	66.2	67.6	69.2	65.9	59.4	52.4	73.8	52.0
II	6250	0.83/230/50-60	102	39.5	49.7	54.9	57.6	56.1	52.6	45.1	36.3	62.0	40.3
I	2650	0.28/230/50-60	13	36.9	47.5	47.6	51.7	46.4	43.8	34.5	29.2	55.2	33.4

* The specified air flow rates correspond to the maximum, mean and minimum flow rates

** Sound pressure level in 3m, Q=2

WIN1-20A-ECVx-0A0

WIND 20 – EXECUTION EC

Fan speed *	Air throughput	Unit current	Power consumption of the unit	Acoustic power in frequency bands (dB)								Noise level	
				63 Hz	125 Hz	250 Hz	500 Hz	1 kHz	2 kHz	4 kHz	8 kHz	LwA	LPA*
				dB	dB	dB	dB	dB	dB	dB	dB	dB	dB
	m3/h	A/230V/Hz	W										
III	9000	2.99/230/50-60	450	39.5	59.5	65.1	66.4	67.8	65.6	59.3	51.4	72.8	51.0
II	5250	0.84/230/50-60	115	37.8	45.8	54.4	55.9	55.7	52.3	44.2	34.6	61.0	39.2
I	1700	0.29/230/50-60	14	24.4	39.1	44.1	47.8	42.5	37.6	28.1	23.9	50.7	28.9

* The specified air flow rates correspond to the maximum, mean and minimum flow rates

** Sound pressure level in 3m, Q=2

WIN1-20B-ECS0-0A0

WIND 20 – EXECUTION EC

Fan speed *	Air throughput	Unit current	Power consumption of the unit	Acoustic power in frequency bands (dB)								Noise level	
				63 Hz	125 Hz	250 Hz	500 Hz	1 kHz	2 kHz	4 kHz	8 kHz	LwA	LPA*
				dB	dB	dB	dB	dB	dB	dB	dB	dB	dB
	m3/h	A/230V/Hz	W										
III	12000	4.53/230/50-60	687	46.2	68.3	76.6	78.4	80.1	77.4	70.5	61.6	84.6	62.7
II	7300	1.59/230/50-60	232	39.0	59.4	68.0	67.9	69.5	66.6	58.5	48.2	74.4	52.5
I	4450	0.31/230/50-60	23	19.6	38.3	61.0	44.1	42.9	35.8	27.9	24.6	61.2	39.3

* The specified air flow rates correspond to the maximum, mean and minimum flow rates

** Sound pressure level in 3m, Q=2

WIN1-20B-ECVx-0A0

WIND 20 – EXECUTION EC

Fan speed *	Air throughput	Unit current	Power consumption of the unit	Acoustic power in frequency bands (dB)								Noise level	
				63 Hz	125 Hz	250 Hz	500 Hz	1 kHz	2 kHz	4 kHz	8 kHz	LwA	LPA*
				dB	dB	dB	dB	dB	dB	dB	dB	dB	dB
	m3/h	A/230V/Hz	W										
III	10400	4.52/230/50-60	708	45.1	66.4	76.1	76.1	77.3	75.1	68.4	59.1	82.5	60.6
II	6900	1.74/230/50-60	272	41.5	58.6	67.8	66.9	68.3	65.9	57.6	47.2	73.6	51.7
I	2600	0.31/230/50-60	25	22.6	37.2	57.4	44.0	42.0	35.9	29.5	26.3	57.8	35.9

* The specified air flow rates correspond to the maximum, mean and minimum flow rates

** Sound pressure level in 3m, Q=2

WIN1-25A-ECS0-0A0

WIND 25 – EXECUTION EC

Fan speed *	Air throughput	Unit current	Power consumption of the unit	Acoustic power in frequency bands (dB)								Noise level	
				63 Hz	125 Hz	250 Hz	500 Hz	1 kHz	2 kHz	4 kHz	8 kHz	LwA	LPA*
				dB	dB	dB	dB	dB	dB	dB	dB	dB	dB
	m3/h	A/230V/Hz	W										
III	12900	3.57/230/50-60	528	43.9	61.4	67.5	68.8	70.4	67.1	60.5	53.4	75.0	53.2
II	7800	1.03/230/50-60	128	40.9	51.0	56.2	58.9	57.4	53.8	46.2	37.3	63.2	41.5
I	3350	0.35/230/50-60	16	38.4	48.8	48.9	52.9	47.6	45.0	35.6	30.2	56.4	34.6

* The specified air flow rates correspond to the maximum, mean and minimum flow rates

** Sound pressure level in 3m, Q=2

WIN1-25A-ECVx-0A0

WIND 25 – EXECUTION EC

Fan speed *	Air throughput	Unit current	Power consumption of the unit	Acoustic power in frequency bands (dB)								Noise level	
				63 Hz	125 Hz	250 Hz	500 Hz	1 kHz	2 kHz	4 kHz	8 kHz	LwA	LPA*
				dB	dB	dB	dB	dB	dB	dB	dB	dB	dB
	m3/h	A/230V/Hz	W										
III	11250	3.73/230/50-60	562	41.1	61.0	66.5	67.8	69.2	66.9	60.5	52.5	74.1	52.3
II	6550	1.05/230/50-60	144	39.3	47.2	55.8	57.3	57.0	53.6	45.4	35.7	62.3	40.5
I	2150	0.37/230/50-60	17	26.0	40.5	45.5	49.1	43.8	38.8	29.3	25.0	52.0	30.2

* The specified air flow rates correspond to the maximum, mean and minimum flow rates

** Sound pressure level in 3m, Q=2

WIN1-25B-ECS0-0A0

WIND 25 – EXECUTION EC

Fan speed *	Air throughput	Unit current	Power consumption of the unit	Acoustic power in frequency bands (dB)								Noise level	
				63 Hz	125 Hz	250 Hz	500 Hz	1 kHz	2 kHz	4 kHz	8 kHz	LwA	LPA*
				dB	dB	dB	dB	dB	dB	dB	dB	dB	dB
	m3/h	A/230V/Hz	W										
III	15000	5.42/230/50-60	822	47.7	69.5	78.2	79.7	81.2	78.3	71.4	62.3	85.8	63.7
II	9100	1.97/230/50-60	287	40.5	61.2	69.7	69.2	70.5	67.6	59.5	49.0	75.7	53.6
I	5550	0.37/230/50-60	28	26.7	39.8	62.0	47.0	44.6	38.1	32.3	28.4	62.3	40.1

* The specified air flow rates correspond to the maximum, mean and minimum flow rates

** Sound pressure level in 3m, Q=2

WIN1-25B-ECVx-0A0

WIND 25 – EXECUTION EC

Fan speed *	Air throughput	Unit current	Power consumption of the unit	Acoustic power in frequency bands (dB)								Noise level	
				63 Hz	125 Hz	250 Hz	500 Hz	1 kHz	2 kHz	4 kHz	8 kHz	LwA	LPA*
				dB	dB	dB	dB	dB	dB	dB	dB	dB	dB
	m3/h	A/230V/Hz	W										
III	13000	5.45/230/50-60	853	47.3	68.3	77.5	77.5	78.6	76.2	69.4	59.8	83.9	61.7
II	8650	2.24/230/50-60	351	42.6	61.3	69.3	68.4	69.5	66.9	58.6	47.7	75.0	52.8
I	3250	0.38/230/50-60	31	33.3	42.2	61.4	47.1	45.1	41.2	35.5	29.2	61.8	39.7

* The specified air flow rates correspond to the maximum, mean and minimum flow rates

** Sound pressure level in 3m, Q=2

Water heater parameters



WINI-15A-ECVI-OAO

WIND 15 – EXECUTION EC

Inlet air temperature	Air flow	90/70				80/60				70/50				60/40				50/30			
		Heating capacity of the heater	Exhaust air temperature	Water flow	Pressure loss - water	Heating capacity of the heater	Exhaust air temperature	Water flow	Pressure loss - water	Heating capacity of the heater	Exhaust air temperature	Water flow	Pressure loss - water	Heating capacity of the heater	Exhaust air temperature	Water flow	Pressure loss - water	Heating capacity of the heater	Exhaust air temperature	Water flow	Pressure loss - water
°C	m3/h	kW	°C	m3/h	kPa	kW	°C	m3/h	kPa	kW	°C	m3/h	kPa	kW	°C	m3/h	kPa	kW	°C	m3/h	kPa
0	7000	32,62	12,9	1,45	12,7	28,01	11,1	1,24	13,8	23,4	9,3	1,03	10	18,75	7,4	0,82	12,3	14	5,6	0,61	7,3
	4900	28,84	16,3	1,28	14,4	24,79	14	1,1	11	20,72	11,7	0,91	7,9	16,63	9,4	0,73	9,8	12,52	7,1	0,55	5,8
	3000	24,01	22,2	1,07	10,2	20,66	19,1	0,91	7,8	17,31	16	0,76	10,4	13,92	12,9	0,61	7	10,48	9,7	0,46	4,2
5	7000	30,32	17,2	1,35	11,1	25,72	15,4	1,14	11,8	21,14	13,5	0,93	8,2	16,5	11,7	0,72	9,7	11,86	9,8	0,52	5,3
	4900	26,79	20,4	1,19	12,6	22,77	18,1	1,01	9,3	18,71	15,8	0,82	12,1	14,65	13,4	0,64	7,7	10,51	11,1	0,46	4,2
	3000	22,3	26	0,99	8,9	18,97	22,8	0,84	6,6	15,63	19,7	0,69	8,6	12,27	16,5	0,54	5,5	8,65	13,1	0,38	9,5
10	7000	28,2	21,5	1,24	13,7	23,46	19,6	1,04	9,9	18,87	17,7	0,83	12,3	14,28	15,9	0,63	7,4	9,48	13,9	0,41	11,2
	4900	24,77	24,5	1,1	10,8	20,75	22,2	0,92	7,8	16,73	19,8	0,74	9,8	12,69	17,4	0,56	5,9	8,23	14,8	0,36	8,6
	3000	20,61	29,7	0,92	7,7	17,31	26,6	0,76	10,3	13,97	23,4	0,61	7	10,64	20,2	0,47	4,2	6,66	16,4	0,29	5,8
15	7000	25,75	25,7	1,14	11,7	21,22	23,8	0,94	8,2	16,65	21,9	0,73	9,7	12,07	20	0,53	5,4	6,62	17,8	0,29	5,7
	4900	22,78	28,6	1,01	9,3	18,76	26,2	0,83	12	14,76	23,8	0,65	7,7	10,73	21,4	0,47	4,3	5,75	18,4	0,25	4,4
	3000	18,94	33,4	0,84	6,5	15,65	30,2	0,69	8,5	12,34	27	0,54	5,5	9	23,7	0,39	10	4,75	19,6	0,21	3,1

WINI-15B-ECVI-OAO

WIND 15 – EXECUTION EC

Inlet air temperature	Air flow	90/70				80/60				70/50				60/40				50/30			
		Heating capacity of the heater	Exhaust air temperature	Water flow	Pressure loss - water	Heating capacity of the heater	Exhaust air temperature	Water flow	Pressure loss - water	Heating capacity of the heater	Exhaust air temperature	Water flow	Pressure loss - water	Heating capacity of the heater	Exhaust air temperature	Water flow	Pressure loss - water	Heating capacity of the heater	Exhaust air temperature	Water flow	Pressure loss - water
°C	m3/h	kW	°C	m3/h	kPa	kW	°C	m3/h	kPa	kW	°C	m3/h	kPa	kW	°C	m3/h	kPa	kW	°C	m3/h	kPa
0	8300	34,51	11,5	1,53	14,1	29,64	9,9	1,31	15,4	24,73	8,3	1,09	11	19,82	6,6	0,87	7,4	14,85	5	0,65	8
	6100	31,13	14,1	1,38	11,6	26,75	12,2	1,18	12,6	22,35	10,2	0,98	9,1	17,92	8,1	0,78	11,3	13,46	6,1	0,59	6,7
	4000	26,8	18,6	1,19	12,6	23,06	16	1,02	9,6	19,27	13,3	0,85	6,9	15,49	10,7	0,68	8,6	11,67	8,1	0,51	5,1
5	8300	32,06	15,9	1,42	12,3	27,2	14,2	1,2	13,1	22,33	12,6	0,98	9,1	17,43	10,9	0,76	10,7	12,5	9,3	0,54	5,8
	6100	28,93	18,4	1,28	14,45	24,56	16,4	1,09	10,8	20,17	14,3	0,89	7,5	15,77	12,3	0,69	8,9	11,35	10,2	0,49	4,8
	4000	24,9	22,6	1,11	10,9	21,15	19,9	0,93	8,1	17,4	17,3	0,77	10,6	13,65	14,6	0,6	6,8	9,75	11,9	0,42	11,8
10	8300	29,66	20,3	1,32	15,2	24,81	18,6	1,1	11	19,97	16,9	0,88	7,4	15,08	15,2	0,66	8,1	10,07	13,5	0,44	3,9
	6100	26,74	22,6	1,19	12,5	22,4	20,5	0,99	9,1	18,03	18,5	0,79	11,3	13,65	16,4	0,6	6,8	9	14,2	0,39	10,2
	4000	23	26,5	1,02	9,4	19,29	23,8	0,85	6,8	15,56	21,2	0,68	8,5	11,1	18,5	0,52	5,1	7,54	15,4	0,33	7,3
15	8300	27,25	24,6	1,21	13	22,43	22,9	0,99	9,1	17,59	21,2	0,77	10,8	12,74	19,5	0,56	5,9	7,09	17,5	0,31	6,5
	6100	24,58	26,8	1,09	10,7	20,25	24,7	0,89	7,5	15,9	22,6	0,7	8,9	11,55	20,5	0,51	4,9	6,27	18	0,27	5,2
	4000	21,14	30,4	0,94	8	17,44	27,7	0,77	10,5	13,73	25	0,6	6,7	10	22,3	0,44	3,8	5,31	18,9	0,23	3,8

Water heater parameters



WIN1-15A-ECV2-0A0

WIND 15 – EXECUTION EC

Inlet air temperature	Airflow	90/70				80/60				70/50				60/40				50/30			
		Heating capacity of the heater	Exhaust air temperature	Water flow	Pressure loss in water	Heating capacity of the heater	Exhaust air temperature	Water flow	Pressure loss in water	Heating capacity of the heater	Exhaust air temperature	Water flow	Pressure loss in water	Heating capacity of the heater	Exhaust air temperature	Water flow	Pressure loss in water	Heating capacity of the heater	Exhaust air temperature	Water flow	Pressure loss in water
°C	m3/h	kW	°C	m3/h	kPa	kW	°C	m3/h	kPa	kW	°C	m3/h	kPa	kW	°C	m3/h	kPa	kW	°C	m3/h	kPa
0	6750	63.4	28.8	2.79	33	55.4	24.9	2.43	26	47.2	20.9	2.07	20	38.9	17	1.69	15	30.3	13.1	1.32	10
	3950	44.6	35.4	1.97	17	39.1	30.5	1.72	14	33.5	25.8	1.47	11	27.7	21	1.21	8	21.8	16.2	0.94	5
	1300	20.5	49.6	0.9	4	18.1	43	0.8	4	15.7	36.4	0.69	3	13.1	29.8	0.57	2	10.4	23.2	0.45	1
5	6750	58.9	32.1	2.59	29	50.9	28.1	2.24	23	42.7	24.2	1.87	17	34.4	20.2	1.5	12	25.9	16.3	1.12	7
	3950	41.5	38.2	1.83	15	36	33.4	1.58	12	30.4	28.6	1.33	9	24.6	23.8	1.07	6	18.6	19	0.81	4
	1300	19.1	51.5	0.84	4	16.7	44.9	0.73	3	14.3	38.3	0.62	2	11.7	31.7	0.51	2	8.98	25.1	0.39	1
10	6750	54.5	35.3	2.4	25	46.5	31.3	2.04	19	38.4	27.4	1.68	14	30	23.4	1.31	9	21.5	19.5	0.93	5
	3950	35.4	41	1.69	13	32.9	36.2	1.45	10	27.3	31.4	1.19	8	21.5	26.6	0.94	5	15.5	21.8	0.67	3
	1300	17.7	53.5	0.78	3	15.3	46.8	0.67	3	12.9	40.3	0.56	2	10.3	33.6	0.45	1	7.55	27	0.33	1
15	6750	50.1	38.5	2.21	22	42.1	34.5	1.85	16	34	30.6	1.49	11	25.7	26.6	1.12	7	17.1	22.6	0.74	3
	3950	35.4	43.9	1.56	11	29.9	39	1.31	9	24.2	34.2	1.06	6	18.4	29.4	0.8	4	12.4	24.5	0.54	2
	1300	16.4	55.4	0.72	3	14	48.8	0.61	2	11.5	42.1	0.5	2	8.85	35.5	0.39	1	6.09	28.8	0.26	1

WIN1-15B-ECV2-0A0

WIND 15 – EXECUTION EC

Inlet air temperature	Airflow	90/70				80/60				70/50				60/40				50/30			
		Heating capacity of the heater	Exhaust air temperature	Water flow	Pressure loss in water	Heating capacity of the heater	Exhaust air temperature	Water flow	Pressure loss in water	Heating capacity of the heater	Exhaust air temperature	Water flow	Pressure loss in water	Heating capacity of the heater	Exhaust air temperature	Water flow	Pressure loss in water	Heating capacity of the heater	Exhaust air temperature	Water flow	Pressure loss in water
°C	m3/h	kW	°C	m3/h	kPa	kW	°C	m3/h	kPa	kW	°C	m3/h	kPa	kW	°C	m3/h	kPa	kW	°C	m3/h	kPa
0	7800	69.3	27.2	3.05	37	60.5	23.4	2.66	30	51.6	19.7	2.26	24	42.4	16	1.85	17	33	12.3	1.43	13
	5200	53.6	32	2.36	24	46.9	27.6	2.06	20	40.1	23.2	1.75	15	33.1	18.9	1.44	13	25.9	14.6	1.12	10
	1950	27	44.6	1.19	8	23.8	38.6	1.04	8	20.5	32.6	0.9	6	17.1	26.7	0.75	6	13.6	20.7	0.59	4
5	7800	64.4	30.5	2.84	32	55.6	26.8	2.44	27	46.7	23	2.04	20	37.5	19.3	1.64	14	28.2	15.6	1.22	10
	5200	49.8	35	2.19	21	43.1	30.6	1.89	17	36.3	26.3	1.59	13	29.3	21.9	1.28	10	22.1	17.6	0.96	7
	1950	25.1	46.9	1.11	9	21.9	40.9	0.96	7	18.7	34.9	0.82	5	15.2	28.9	0.66	5	11.6	22.9	0.51	3
10	7800	59.6	33.9	2.62	29	50.8	30.1	2.23	23	41.9	26.4	1.83	16	32.7	22.6	1.41	12	23.3	18.9	1.01	8
	5200	46.1	38.1	2.03	19	39.4	33.7	1.73	14	32.6	29.3	1.43	12	25.6	24.9	1.12	9	18.4	20.6	0.8	5
	1950	23.3	49.1	1.03	7	20.1	43.1	0.88	6	16.8	37.1	0.74	6	13.4	31.1	0.58	4	9.73	25.1	0.42	4
15	7800	54.8	37.2	2.41	25	46	33.4	2.02	19	37.1	29.7	1.62	13	28	25.9	1.22	9	18.5	22.1	0.8	5
	5200	45.4	41.1	1.87	18	35.8	36.7	1.57	12	29	32.3	1.27	10	21.9	27.9	0.96	7	14.6	23.5	0.64	5
	1950	21.5	51.4	0.95	6	18.3	45.3	0.8	5	15	39.3	0.66	5	11.5	33.3	0.5	3	7.84	27.5	0.34	3

Water heater parameters



WIN1-20A-ECV1-0A0

WIND 20 – EXECUTION EC

Inlet air temperature	Air flow	90/70				80/60				70/50				60/40				50/30			
		Heating capacity of the heater	Exhaust air temperature	Water flow	Pressure loss - water	Heating capacity of the heater	Exhaust air temperature	Water flow	Pressure loss - water	Heating capacity of the heater	Exhaust air temperature	Water flow	Pressure loss - water	Heating capacity of the heater	Exhaust air temperature	Water flow	Pressure loss - water	Heating capacity of the heater	Exhaust air temperature	Water flow	Pressure loss - water
°C	m3/h	kW	°C	m3/h	kPa	kW	°C	m3/h	kPa	kW	°C	m3/h	kPa	kW	°C	m3/h	kPa	kW	°C	m3/h	kPa
0	9300	45,1	13,4	2	26,3	38,9	11,6	1,72	20,2	32,66	9,7	1,44	14,8	26,4	7,9	1,16	13,9	20,1	6	0,88	8,5
	6900	40,66	16,3	1,81	21,7	35	14	1,55	16,7	29,5	11,9	1,3	16,9	23,88	9,6	1,05	11,5	18,21	7,3	0,73	12,5
	4200	33,78	22,3	1,5	15,3	29,18	19,3	1,29	16,3	24,5	16,2	1,08	12	19,9	13,2	0,87	8,2	15,26	10,1	0,66	8,9
5	9300	41,95	17,7	1,86	22,9	35,76	15,8	1,58	17,3	29,59	14	1,3	17	23,35	12,1	1,02	11,1	17	10,2	0,74	11
	6900	37,82	20,5	1,68	18,9	32,26	18,2	1,43	14,2	26,7	15,9	1,17	14	21,1	13,6	0,92	9,2	15,5	11,3	0,67	9,2
	4200	31,4	26,1	1,39	13,4	26,84	23	1,19	13,9	22,24	19,9	0,98	9,9	17,6	16,8	0,77	11,6	12,96	13,7	0,56	6,6
10	9300	38,84	22	1,73	19,9	32,67	20,1	1,44	14,6	26,5	18,8	1,17	13,8	20,3	16,3	0,89	8,5	14	14,3	0,61	7,6
	6900	34,99	24,6	1,55	16,4	29,5	22,3	1,3	16,6	23,94	20	1,05	11,4	18,36	17,6	0,8	12,5	12,7	15,3	0,55	6,4
	4200	29,07	29,9	1,29	16	24,5	26,8	1,08	11,8	19,94	23,6	0,88	8,1	15,36	20,5	0,67	8,9	10,67	17,3	0,46	4,6
15	9300	35,73	26,2	1,59	17	29,63	24,3	1,31	16,8	23,46	22,4	1,03	11	17,2	20,4	0,76	11,1	11	18,4	0,48	4,8
	6900	32,2	28,6	1,43	14	26,7	26,3	1,18	13,8	21,19	24	0,93	9,1	15,6	21,6	0,68	9,2	9,87	19,2	0,43	12,3
	4200	26,75	33,6	1,19	13,7	22,22	30,4	0,98	9,8	17,67	27,3	0,78	11,5	13,08	24,1	0,57	6,6	8	20,6	0,35	8,4

WIN1-20B-ECV1-0A0

WIND 20 – EXECUTION EC

Inlet air temperature	Air flow	90/70				80/60				70/50				60/40				50/30			
		Heating capacity of the heater	Exhaust air temperature	Water flow	Pressure loss - water	Heating capacity of the heater	Exhaust air temperature	Water flow	Pressure loss - water	Heating capacity of the heater	Exhaust air temperature	Water flow	Pressure loss - water	Heating capacity of the heater	Exhaust air temperature	Water flow	Pressure loss - water	Heating capacity of the heater	Exhaust air temperature	Water flow	Pressure loss - water
°C	m3/h	kW	°C	m3/h	kPa	kW	°C	m3/h	kPa	kW	°C	m3/h	kPa	kW	°C	m3/h	kPa	kW	°C	m3/h	kPa
0	11000	47,7	12	2,12	25,7	41,17	10,4	1,82	22,4	34,52	8,7	1,52	16,4	27,9	7	1,22	15,4	21,24	5,4	0,93	9,4
	8100	43	14,7	1,91	24,1	37,1	12,7	1,64	18,5	31,2	10,7	1,37	13,6	25,2	8,6	1,1	12,8	19,22	6,6	0,84	7,8
	5200	36,66	19,5	1,63	17,8	31,6	16,9	1,4	13,8	26,64	14,2	1,17	13,9	21,6	11,5	0,94	9,5	16,49	8,8	0,72	10,3
5	11000	44,37	16,4	1,97	25,5	37,8	14,7	1,67	19,2	31,25	13	1,37	13,7	24,6	11,3	1,08	12,2	18	9,6	0,78	12,2
	8100	40	18,9	1,78	21	34,12	16,9	1,51	15,8	28,22	14,8	1,24	15,5	22,3	12,8	0,98	10,2	16,32	10,7	0,71	10,1
	5200	34,1	23,5	1,51	15,6	29,11	20,8	1,29	16,2	24,12	18,1	1,06	11,6	19	15,4	0,84	7,6	14	12,6	0,61	7,6
10	11000	41	20,7	1,82	22,1	34,55	19	1,53	16,2	28	17,3	1,23	15,3	21,45	15,6	0,94	9,4	14,8	13,9	0,64	8,4
	8100	37	23,1	1,64	18,2	31,17	21	1,38	13,4	25,3	19	1,11	12,7	19,39	16,9	0,85	7,8	13,42	14,8	0,58	7
	5200	31,54	27,4	1,4	13,5	26,6	24,7	1,18	13,7	21,61	21,9	0,95	9,5	16,61	19,2	0,73	10,3	11,54	16,3	0,5	5,3
15	11000	37,81	25	1,68	18,9	31,3	23,3	1,38	13,5	24,79	21,6	1,09	12,2	18,23	19,8	0,8	12,3	11,6	18,1	0,5	5,3
	8100	34	27	1,51	15,6	28,25	25,2	1,25	15,3	22,4	23,1	0,99	10,1	16,5	20,9	0,72	10,2	10,8	18,8	0,46	4,4
	5200	29	31,3	1,29	16	24,11	28,5	1,07	11,4	19,14	25,7	0,84	7,5	14,2	22,9	0,62	7,7	8,82	19,9	0,38	10

Water heater parameters



WIN1-20A-ECV2-0A0

WIND 20 – EXECUTION EC

Inlet air temperature	Airflow	90/70				80/60				70/50				60/40				50/30			
		Heating capacity of the heater	Exhaust air temperature	Water flow	Pressure loss in water	Heating capacity of the heater	Exhaust air temperature	Water flow	Pressure loss in water	Heating capacity of the heater	Exhaust air temperature	Water flow	Pressure loss in water	Heating capacity of the heater	Exhaust air temperature	Water flow	Pressure loss in water	Heating capacity of the heater	Exhaust air temperature	Water flow	Pressure loss in water
°C	m3/h	kW	°C	m3/h	kPa	kW	°C	m3/h	kPa	kW	°C	m3/h	kPa	kW	°C	m3/h	kPa	kW	°C	m3/h	kPa
0	9000	85.6	29.3	3.77	47	74.9	25.3	3.29	38	64	21.3	2.8	29	52.8	17.4	2.3	22	41.4	13.4	1.8	15
	5250	60	35.9	2.64	25	52.7	31.1	2.31	21	45.2	26.2	1.98	16	37.5	21.4	1.64	12	29.6	16.6	1.28	1.8
	1700	26.3	50.9	1.16	7	23.3	44.2	1.02	7	20.2	37.4	0.89	5	17	30.7	0.74	6	13.6	24.1	0.59	0.6
5	9000	79.3	32.5	3.51	41	68.9	28.5	3.03	33	58	24.5	2.54	26	46.9	20.6	2.04	18	35.4	16.6	1.54	13
	5250	55.8	38.7	2.46	23	48.5	33.9	2.13	18	41	29	1.8	14	33.3	24.2	1.45	11	25.4	19.4	1.1	9
	1700	24.5	52.8	1.08	7	21.6	46	0.95	6	18.4	39.3	0.81	5	15.1	32.6	0.66	5	11.7	25.9	0.51	3
10	9000	73.6	35.7	3.24	36	63	31.7	2.77	28	52.1	27.7	2.28	21	40.9	23.7	1.78	14	29.5	19.8	1.28	9
	5250	51.7	41.5	2.28	20	44.4	36.6	1.95	16	36.9	31.8	1.62	11	29.2	27	1.27	9	21.2	22.1	0.92	6
	1700	22.9	54.6	1.01	7	19.8	47.9	0.87	5	16.6	41.2	0.73	5	13.3	34.5	0.58	4	9.85	27.7	0.43	4
15	9000	67.7	38.9	2.98	31	57.1	34.9	2.51	25	46.2	30.9	2.02	17	35.1	26.9	1.53	13	23.5	22.9	1.02	7
	5250	47.6	44.3	2.1	17	40.3	39.4	1.77	13	32.8	34.6	1.44	11	25.1	29.7	1.09	8	17	24.8	0.74	6
	1700	21.1	56.5	0.93	6	18.1	49.7	0.79	4	14.9	43	0.65	4	11.5	36.3	0.5	3	7.99	29.4	0.35	3

WIN1-20B-ECV2-0A0

WIND 20 – EXECUTION EC

Inlet air temperature	Airflow	90/70				80/60				70/50				60/40				50/30			
		Heating capacity of the heater	Exhaust air temperature	Water flow	Pressure loss in water	Heating capacity of the heater	Exhaust air temperature	Water flow	Pressure loss in water	Heating capacity of the heater	Exhaust air temperature	Water flow	Pressure loss in water	Heating capacity of the heater	Exhaust air temperature	Water flow	Pressure loss in water	Heating capacity of the heater	Exhaust air temperature	Water flow	Pressure loss in water
°C	m3/h	kW	°C	m3/h	kPa	kW	°C	m3/h	kPa	kW	°C	m3/h	kPa	kW	°C	m3/h	kPa	kW	°C	m3/h	kPa
0	10400	93.6	27.6	4.13	54	81.9	23.8	3.6	45	69.9	20.1	3.06	34	57.6	16.3	2.51	26	45.1	12.6	1.96	17
	6900	72.1	32.5	3.18	35	63.2	28.1	2.78	28	54.1	23.7	2.37	23	44.8	19.3	1.95	17	35.2	14.9	1.53	13
	2600	36.3	45.1	1.6	11	32.1	39.1	1.41	10	27.7	33.1	1.21	8	23.1	27.1	1.01	7	18.4	21.1	0.8	5
5	10400	87.1	30.9	3.84	49	75.3	27.1	3.31	38	63.4	23.4	2.77	29	51.1	19.6	2.23	21	38.6	15.9	1.67	13
	6900	67	35.5	2.95	30	85.1	31.1	2.55	26	49.1	26.7	2.15	19	39.7	22.3	1.73	13	30.2	17.9	1.31	10
	2600	33.9	47.4	1.49	11	29.6	41.3	1.3	9	25.2	35.4	1.1	8	20.6	29.4	0.9	6	15.9	23.4	0.69	5
10	10400	80.6	34.2	3.55	42	68.8	30.5	3.02	33	56.9	26.7	2.49	25	44.6	22.9	1.94	17	32	19.2	1.39	11
	6900	62.1	38.5	2.74	27	53.2	34.1	2.34	22	44.1	29.7	1.93	16	34.8	25.3	1.52	12	25.1	20.9	1.09	8
	2600	31.4	49.6	1.38	10	27.1	43.6	1.19	8	22.7	37.6	0.99	7	18.1	31.5	0.79	5	13.3	25.5	0.58	4
15	10400	74.1	37.5	3.26	36	62.4	33.7	2.74	27	50.5	30	2.21	20	38.2	26.2	1.67	13	25.6	22.4	1.11	9
	6900	57.1	41.5	2.52	24	48.3	37.1	2.12	18	39.2	32.7	1.71	13	29.8	28.3	1.3	9	20.1	23.8	0.87	6
	2600	29	51.8	1.28	8	24.7	45.8	1.08	8	20.2	39.8	0.89	5	15.6	33.7	0.68	5	10.7	27.6	0.47	5

Water heater parameters



WIN1-25A-ECV1-0A0

WIND 25 – EXECUTION EC

Inlet air temperature	Air flow	90/70				80/60				70/50				60/40				50/30			
		Heating capacity of the heater	Exhaust air temperature	Water flow	Pressure loss - water	Heating capacity of the heater	Exhaust air temperature	Water flow	Pressure loss - water	Heating capacity of the heater	Exhaust air temperature	Water flow	Pressure loss - water	Heating capacity of the heater	Exhaust air temperature	Water flow	Pressure loss - water	Heating capacity of the heater	Exhaust air temperature	Water flow	Pressure loss - water
°C	m3/h	kW	°C	m3/h	kPa	kW	°C	m3/h	kPa	kW	°C	m3/h	kPa	kW	°C	m3/h	kPa	kW	°C	m3/h	kPa
0	11900	58	13,5	2,58	41,6	50,2	11,7	2,22	32,3	42,3	9,9	1,86	26,8	34,4	8	1,5	18,6	26,4	6,2	1,15	15,4
	8500	51,6	16,8	2,29	33,5	44,6	14,6	1,97	29,1	37,7	12,3	1,66	21,6	30,7	10	1,34	15	23,6	7,7	1	12,5
	5500	43,9	22,1	1,95	27,7	38	19,2	1,68	21,6	32	16,2	1,41	16	26,16	13,2	1,14	14,9	20,16	10,2	0,88	9,4
5	11900	54	17,8	2,4	36,4	46,22	16	2,04	27,7	38,4	14,1	1,69	22,3	30,5	12,2	1,33	14,9	22,5	10,3	1	11,5
	8500	48	21	2,13	29,3	41,13	18,6	1,82	25	34,2	16,3	1,5	18	27,17	14	1,19	16	20,1	11,7	0,88	9,3
	5500	40,8	25,9	1,81	24,3	35	22,9	1,55	18,5	29	19,9	1,28	17,9	23,18	16,9	1	11,9	17,21	13,8	0,75	11,8
10	11900	50	22,1	2,22	31,6	42,3	20,2	1,87	26,3	34,44	18,3	1,51	18,3	26,5	16,4	1,16	15,3	18,6	14,5	0,8	13,7
	8500	44,5	25	1,98	28,5	37,6	22,7	1,66	21,1	30,68	20,4	1,35	14,8	23,71	18	1	12,4	16,6	15,6	0,73	11,1
	5500	37,8	29,7	1,68	21,1	32	26,7	1,41	15,7	26,13	23,6	1,15	14,6	20,2	20,6	0,89	9,2	14,2	17,4	0,6	8,3
15	11900	46	26,3	2	27,2	38,36	24,4	1,7	21,9	30,55	22,5	1,34	14,7	22,7	20,6	0,99	11,4	14,7	18,6	0,64	8,8
	8500	41	29	1,82	24,5	34,12	26,7	1,51	17,7	27,21	24,3	1,2	15,8	20,2	22	0,89	9,3	13,17	19,5	0,57	7,2
	5500	34,8	33,5	1,55	18,1	29	30,4	1,28	17,5	23,2	27,3	1,02	11,7	17,3	24,2	0,76	11,8	11,3	21	0,49	5,4

WIN1-25B-ECV1-0A0

WIND 25 – EXECUTION EC

Inlet air temperature	Air flow	90/70				80/60				70/50				60/40				50/30			
		Heating capacity of the heater	Exhaust air temperature	Water flow	Pressure loss - water	Heating capacity of the heater	Exhaust air temperature	Water flow	Pressure loss - water	Heating capacity of the heater	Exhaust air temperature	Water flow	Pressure loss - water	Heating capacity of the heater	Exhaust air temperature	Water flow	Pressure loss - water	Heating capacity of the heater	Exhaust air temperature	Water flow	Pressure loss - water
°C	m3/h	kW	°C	m3/h	kPa	kW	°C	m3/h	kPa	kW	°C	m3/h	kPa	kW	°C	m3/h	kPa	kW	°C	m3/h	kPa
0	13500	60,58	12,4	2,69	40	52,3	10,8	2,31	34,9	44	9,1	1,94	28,9	35,85	7,4	1,57	20,1	27,5	5,6	1,2	16,7
	9900	54,5	15,3	2,42	37	47,15	13,2	2,08	28,7	39,8	11,1	1,75	23,9	32,3	9	1,41	16,6	24,85	7	1,1	13,8
	6100	45,67	20,8	2	26,7	39,6	18	1,75	23,2	33,3	15,2	1,47	17,3	27,2	12,4	1,19	16	21	9,5	0,9	10
5	13500	56,39	16,8	2,5	39,4	48,2	15,1	2,13	29,9	40	13,4	1,76	24,1	31,76	11,6	1,39	16	23,4	10	1,02	12,4
	9900	50,73	19,5	2,25	32,4	43,4	17,4	1,92	27,6	36	15,3	1,58	19,9	28,6	13,2	1,25	17,6	21,2	11	0,9	10,3
	6100	42,5	24,7	1,89	26,1	36,38	21,8	1,61	19,9	30,2	19	1,33	14,4	24	16,2	1,06	12,8	17,9	13,3	0,8	12,7
10	13500	52,2	21,1	2,32	34,2	44	19,4	1,95	28,4	35,9	17,6	1,58	19,8	27,7	15,9	1,21	16,6	19,39	14,1	0,85	8,7
	9900	47	23,6	2,09	28,1	39,7	21,5	1,75	23,4	32,35	19,4	1,42	16,3	25	17,2	1,1	13,7	17,5	15	0,76	12,2
	6100	39,4	28,5	1,75	22,7	33,26	25,7	1,47	16,8	27,2	22,8	1,19	15,7	21	19,9	0,92	9,9	14,8	17	0,65	8,9
15	13500	48,1	25,4	2,14	29,4	40	23,7	1,77	23,7	31,8	21,9	1,4	15,8	23,6	20,1	1,03	12,4	15,3	18,3	0,67	9,5
	9900	43	27,8	1,92	27,1	36	25,6	1,59	19,5	28,8	23,4	1,27	17,5	21,3	21,3	0,9	10,2	13,85	19,1	0,6	7,9
	6100	36,2	32,3	1,61	19,5	30,2	29,4	1,33	14,1	24,1	26,5	1,06	12,6	17,98	23,6	0,8	12,6	11,7	20,6	0,5	5,8

Water heater parameters



WIN1-25A-ECV2-0A0

WIND 25 – EXECUTION EC

Inlet air temperature	Airflow	90/70				80/60				70/50				60/40				50/30			
		Heating capacity of the heater	Exhaust air temperature	Water flow	Pressure loss in water	Heating capacity of the heater	Exhaust air temperature	Water flow	Pressure loss in water	Heating capacity of the heater	Exhaust air temperature	Water flow	Pressure loss in water	Heating capacity of the heater	Exhaust air temperature	Water flow	Pressure loss in water	Heating capacity of the heater	Exhaust air temperature	Water flow	Pressure loss in water
°C	m3/h	kW	°C	m3/h	kPa	kW	°C	m3/h	kPa	kW	°C	m3/h	kPa	kW	°C	m3/h	kPa	kW	°C	m3/h	kPa
0	11250	107	29.2	4.7	31	93.4	25.2	4.1	25	79.7	21.2	3.49	20	65.6	17.2	2.86	15	51.3	13.3	2.23	11
	6550	74.8	35.9	3.29	17	65.6	31	2.88	14	56.2	26.1	2.46	12	46.5	21.3	2.03	9	36.6	16.5	1.59	6
	2150	33.1	50.7	1.46	6	29.3	43.9	1.29	5	25.4	37.2	1.11	5	21.3	30.5	0.93	4	17	23.8	0.74	4
5	11250	99.3	32.5	4.37	28	85.9	28.4	3.77	23	72.2	24.4	3.16	17	58.1	20.4	2.53	13	43.7	16.5	1.9	8
	6550	69.5	38.7	3.06	15	60.4	33.8	2.65	12	51	28.9	2.23	10	41.3	24.1	1.8	7	31.3	19.2	1.36	6
	2150	30.9	52.6	1.36	5	27.1	45.8	1.19	4	23.1	39.1	1.01	4	19	32.4	0.83	3	14.6	25.6	0.63	3
10	11250	91.8	35.7	4.05	24	78.4	31.6	3.45	19	64.7	27.6	2.83	14	50.8	23.6	2.21	10	36.3	19.6	1.58	6
	6550	64.4	41.5	2.84	13	55.3	36.6	2.43	12	45.8	31.7	2.01	8	36.1	26.8	1.58	6	26.1	22	1.13	4
	2150	28.7	54.4	1.27	5	24.9	47.7	1.09	5	20.9	41	0.91	4	16.7	34.2	0.73	4	12.3	27.5	0.53	2
15	11250	84.4	38.8	3.72	22	71.1	34.8	3.12	16	57.4	30.8	2.51	13	43.4	26.8	1.89	8	28.9	22.7	1.25	5
	6550	59.3	44.2	2.61	13	50.1	39.3	2.2	10	40.7	34.5	1.78	7	31	29.6	1.35	6	20.9	24.7	0.91	4
	2150	26.5	56.3	1.17	4	22.6	49.5	0.99	4	18.7	42.8	0.82	3	14.4	36	0.63	3	9.93	29.2	0.43	4

WIN1-25B-ECV2-0A0

WIND 25 – EXECUTION EC

Inlet air temperature	Airflow	90/70				80/60				70/50				60/40				50/30			
		Heating capacity of the heater	Exhaust air temperature	Water flow	Pressure loss in water	Heating capacity of the heater	Exhaust air temperature	Water flow	Pressure loss in water	Heating capacity of the heater	Exhaust air temperature	Water flow	Pressure loss in water	Heating capacity of the heater	Exhaust air temperature	Water flow	Pressure loss in water	Heating capacity of the heater	Exhaust air temperature	Water flow	Pressure loss in water
°C	m3/h	kW	°C	m3/h	kPa	kW	°C	m3/h	kPa	kW	°C	m3/h	kPa	kW	°C	m3/h	kPa	kW	°C	m3/h	kPa
0	13000	117	27.5	5.15	37	102	23.7	4.48	30	87	20	3.81	24	71.6	16.2	3.12	17	55.8	12.5	2.42	13
	8650	90.1	32.4	3.97	24	78.9	28	3.47	20	67.5	23.6	2.95	15	55.7	19.2	2.43	12	43.6	14.8	1.89	8
	3250	45.3	45.1	2	8	40	39	1.76	6	34.5	33	1.51	7	28.7	27	1.25	5	22.8	21	0.99	4
5	13000	109	30.9	4.79	33	93.9	27.1	4.12	26	78.8	23.3	3.45	20	63.4	19.5	2.76	14	47.6	15.8	2.07	9
	8650	83.8	35.4	3.69	21	72.6	31	3.19	17	61.1	26.6	2.68	13	49.4	22.2	2.15	10	37.3	17.8	1.62	6
	3250	42.3	47.3	1.86	7	36.9	41.3	1.62	5	31.3	35.2	1.37	6	25.6	29.2	1.12	5	19.6	23.2	0.85	3
10	13000	100	34.2	4.43	28	85.7	30.4	3.76	23	70.7	26.6	3.1	16	55.3	22.8	2.41	12	39.5	19	1.72	7
	8650	77.6	38.4	3.42	19	66.4	34	2.92	14	54.9	29.6	2.4	12	43.1	25.1	1.88	8	31	20.7	1.35	6
	3250	39.2	49.5	1.73	6	33.8	43.5	1.49	6	28.2	37.4	1.24	5	22.4	31.4	0.98	4	16.4	25.3	0.71	4
15	13000	92.4	37.5	4.07	24	77.7	33.7	3.41	19	62.6	29.9	2.74	13	47.3	26.1	2.06	9	31.4	22.3	1.36	6
	8650	71.4	41.4	3.15	16	60.2	37	2.64	12	48.8	32.5	2.13	9	37	28.1	1.61	6	24.7	23.6	1.07	5
	3250	36.2	51.7	1.59	5	30.8	45.7	1.35	5	25.2	39.6	1.1	5	19.3	33.6	0.84	3	13.2	27.4	0.57	3



More information



SMART-FLEX Sp. z o.o.
Mielczarskiego 21/23
42-202 Częstochowa

e-mail: biuro@smart-flex.pl
tel: +48 343 444 005
gsm: +48 790 808 005
www.smart-flex.pl