

## Technical parameters

Unit XFLAT			XF1-15-ECS0HRXAS-0A0	XF1-15-ECS0ERXAS-0A0
Type of recovery exchanger			HRV	ERV
Unit equipment *	preheater		electric (max.1kW external preheater)	electric (max.1kW external preheater)
Nominal airflow (external static pressure 150Pa)	m3/h		155	140
Noise level**	dB (A)		39,6	38,8
Weight***	kg		13	13,5
Power supply	V/Hz		1 ~ 230 / 50-60	1 ~ 230 / 50-60
Nominal power input	W		106	101
Recovery efficiency EN308	heat	%	85,1 / -	75 / 66
Protection	IP		20	20
Energy efficiency class (SEC)	-		cold climate A+ ; middle climate A ; warm climate E	cold climate A+ ; middle climate A ; warm climate E

\* the preheater and after-heater are connected directly to the control of the unit and are controlled by its logic

\*\* sound pressure level in (L<sub>WA</sub>) 3m (Q2) - 135m3/h - 110Pa

\*\*\* unit weight (without packaging)

## Basic dimensions



## Accessories



**CO2 room sensor** - after switching the unit to automatic mode, the air flow is regulated based on the CO2 concentration in the room.



**RH room sensor** - after switching the unit to automatic mode, the air flow is regulated based on the concentration of relative humidity in the room.



**CO2 + RH sensor** - after switching the unit to automatic mode, the air flow is regulated based on the concentration of CO2 or relative humidity in the room. Depend on bigger concentration.



**ModbusBox** - extension control module for connection to a superior unit control system. (Modbus).



**AQS extension** - allows to connect up to 8 pcs of air quality sensors



## Ventilation unit with heat and moisture recovery



Xvent s.r.o.  
Poděbradská 289 53009 Pardubice  
Czech Republic

www.xvent.cz

**suitable for apartments and smaller family houses**  
**universal installation location**  
**heat and moisture recovery exchanger**  
**possibility to connect external preheater**  
**easy installation**

...The Xflat unit is focused on maximum utility value for use in apartment buildings. Thanks to its dimensions and MultiPlacing design, the unit can be installed in 6 different positions and in really small installation spaces.

**The unit excels in low weight and low height (only 13kg and 180mm)**

Thanks to the unit's classification in energy class A+. **Xflat** complies with subsidy programs.

**CO2 and RH sensor** can be connected to the unit.

The control also offers the possibility of expansion for remote control and connection to your **smart home**.

The possibility of connecting an external **pre-heater** directly to the unit - thanks to this, pre-heating works only in cases where the unit is in danger of freezing.



The connection sockets are at an angle of 45° and thus allow rigid or flexible ducting without crossing the contour of the unit.

Accessible control - easy connection of necessary accessories.

Filters with high capacity - filter class M5 (alternatively F7).

Two types of heat recovery exchangers. Heat recovery or heat and moisture recovery (enthalpy recovery).

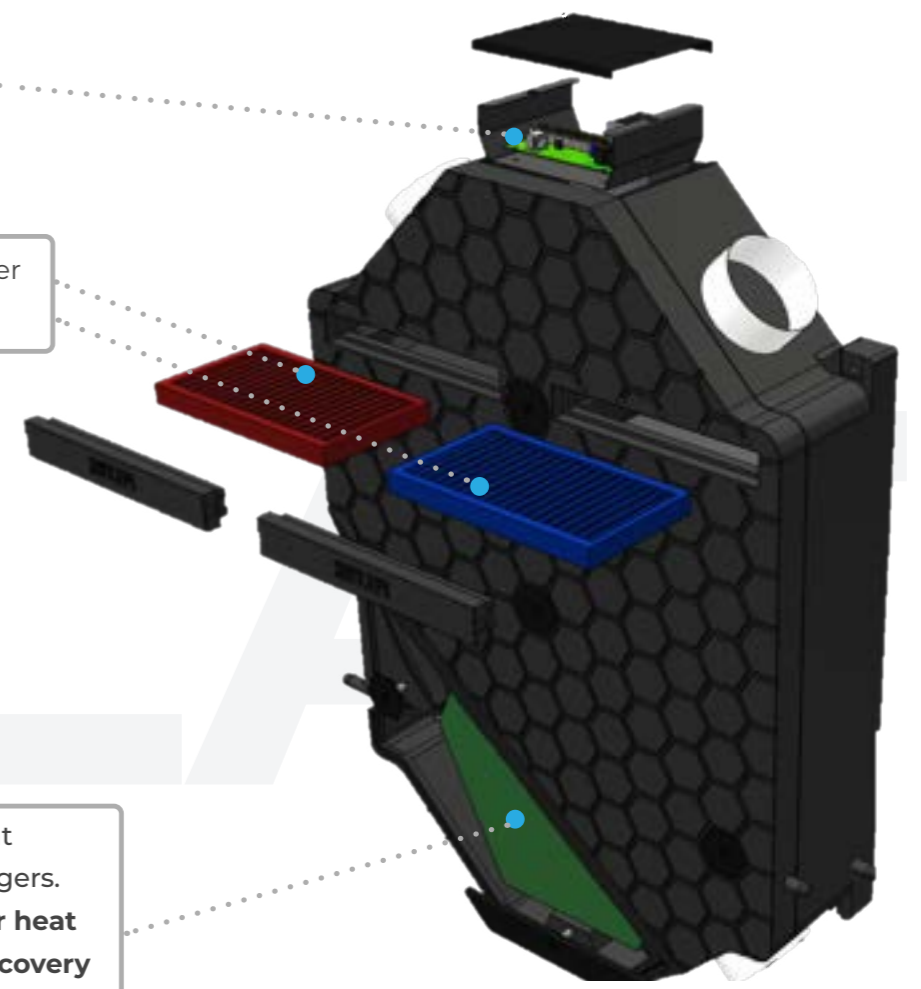

**„MULTIPLACING“ system**

The condensate drain is ready in each position for easier installation. By default, they are all blinded so you only need to cut one and that's it.

**CEILING INSTALLATION**



**WALL HORIZONTAL INSTALLATION**

(Only version with enthalpy exchanger)

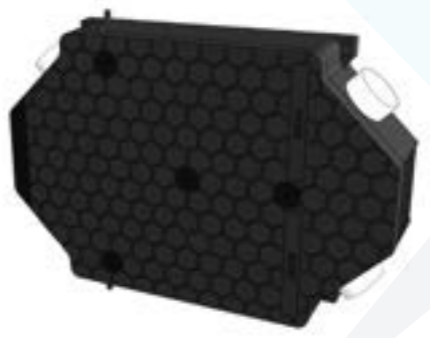

**WALL VERTICAL INSTALLATION**



Wired control is used to control the air output and other functions of unit.

The body of the unit is made from black EPP (expanded polypropylene).

The front EPP cover is removable when needed for major service or cleaning.